



**HAL**  
open science

## Relationships between fluvial evolution and karstification related to climatic, tectonic and eustatic forcing in temperate regions

Dominique Harmand, Kathryn Adamson, Gilles Rixhon, Stéphane Jaillet, Benoît Losson, Alain Devos, Gabriel Hez, Marc Calvet, Philippe Audra

### ► To cite this version:

Dominique Harmand, Kathryn Adamson, Gilles Rixhon, Stéphane Jaillet, Benoît Losson, et al.. Relationships between fluvial evolution and karstification related to climatic, tectonic and eustatic forcing in temperate regions. *Quaternary Science Reviews*, 2017, 166, pp.38 - 56. 10.1016/j.quascirev.2017.02.016 . hal-01690650

**HAL Id: hal-01690650**

**<https://hal.univ-reims.fr/hal-01690650>**

Submitted on 26 Jan 2024

**HAL** is a multi-disciplinary open access archive for the deposit and dissemination of scientific research documents, whether they are published or not. The documents may come from teaching and research institutions in France or abroad, or from public or private research centers.

L'archive ouverte pluridisciplinaire **HAL**, est destinée au dépôt et à la diffusion de documents scientifiques de niveau recherche, publiés ou non, émanant des établissements d'enseignement et de recherche français ou étrangers, des laboratoires publics ou privés.

1     **Relationships between fluvial evolution and karstification related to climatic, tectonic**  
2                             **and eustatic forcing in temperate regions**

3  
4     Dominique Harmand<sup>a</sup>, Kathryn Adamson<sup>b</sup>, Gilles Rixhon<sup>c</sup>, Stéphane Jaillet<sup>d</sup>, Benoît Losson<sup>a</sup>,  
5     Alain Devos<sup>e</sup>, Gabriel Hez<sup>d</sup>, Marc Calvet<sup>f</sup>, Philippe Audra<sup>g</sup>

6  
7     <sup>a</sup>Laboratoire LOTERR, Université de Lorraine, site Libération, BP 13387, 54015 Nancy, (F).  
8     dominique.harmand@univ-lorraine.fr, benoit.losson@univ-lorraine.fr

9     <sup>b</sup>School of Science and The Environment, Manchester Metropolitan University, M1 5GD  
10     Manchester (UK). k.adamson@mmu.ac.uk

11     <sup>c</sup>University of Cologne Institute for Geography, Albertus-Magnus-Platz 50923 Köln (D).  
12     grixhon@uni-koeln.de

13     <sup>d</sup>Laboratoire EDYTEM, Université de Savoie, CNRS, Pôle Montagne, F - 73376 Le Bourget  
14     du Lac (F). Stephane.Jaillet@univ-savoie.fr, gabrielhez@orange.fr

15     <sup>e</sup>Genenaa, 2 esplanade Roland Garros 51100 REIMS (F). alain.devos@univ-reims.fr

16     <sup>f</sup>Université de Perpignan-Via Domitia, UMR 7194 HNHP, 66860 Perpignan Cedex (F).  
17     calvet@univ-perp.fr

18     <sup>g</sup>Polytech Nice - Sophia Université de Nice - Sophia Antipolis 930 route des Colles 06903  
19     Sophia-Antipolis (F). audra@unice.fr

20  
21     **Abstract**

22     This paper reviews the diversity of relationships between river evolution and karstogenesis. It  
23     also underlines the fundamental role of numerical dating methods (e.g. cosmogenic nuclides)  
24     applied to sedimentary sequences in tiered cave passages as they have provided new insights  
25     into these complex interactions. Although karst terrain is widespread worldwide, we focus on  
26     European karst catchments, where the sedimentary records are especially well preserved. We  
27     review the recent dating of fluvial sediments and speleothems, to examine the timing of  
28     karstification, incision and deposition in cave levels. The most complete alluvial records occur  
29     in tectonically uplifted high mountains where some of the oldest sediment fills date to the  
30     Miocene. Evidence indicates that not only uplift, but also climatic conditions and fluvial  
31     dynamics (e.g. knickpoint retreat, increased channel flow and/or sediment load, and stream  
32     piracies) can play a major role in speleogenesis and geomorphological evolution. In evaporite  
33     rocks, speleogenesis is characterized by rapid dissolution and subsidence. In European  
34     catchments, gypsum cave development largely occurred during cold climate periods, while

35 limestone caves formed during warm interglacial or interstadial phases. Our synthesis is used  
36 to propose four models of fluvial and karst evolution, and highlight perspectives for further  
37 research.

38

39 **Keys words:** karst, speleogenesis, valley incision, aggradation, base level, cave level, phreatic  
40 cave, cosmogenic nuclide dating

41

## 42 **1. Introduction: links between karst and fluvial systems**

### 43 **1.1. Conditions and processes of karstification**

44

45 Karst terrain is characterised by underground drainage networks and (sub)surface features such  
46 as dolines, poljes, sinkholes, and caves (Palmer, 2007). It is typical of regions of limestone,  
47 evaporite and marble bedrock, but also develops in siliceous (sandstones and quartzites) and  
48 other metamorphic rocks (Ford & Williams, 1989; Bigot & Audra, 2010). According to Ford  
49 and Williams (1989), karst is globally present in all climate domains, but the widest areas of  
50 karstified terrain are in the limestone and evaporite regions of Europe and Asia (Figure 1).  
51 Karstification is the process of water infiltration and dissolution, mainly through chemical  
52 mechanisms, involving the presence of water and carbonic acid. This definition implies strong  
53 links between karst and fluvial activity, especially for epigenetic speleogenesis which involves  
54 the vertical organization of ‘three karstic horizons’ (Mangin, 1975; Audra & Palmer, 2013): the  
55 infiltration of water at the surface; the flow of water through karstified limestones or evaporites;  
56 and the emergence of water from karst conduits at the valley bottom (Ek, 1961; Delannoy,  
57 1997; Audra, 2010, Figure 2A, 2B). Water flow, and resulting sediment transport, along the  
58 three ‘karstic horizons’ (Mangin, 1975) means that subaerial fluvial forms such as terraces,  
59 often contain only generalized records of palaeo-base and cave levels. Therefore, the core topic  
60 of this contribution focuses on the combined analysis of surface alluvial sequences and  
61 subterranean (endokarst) geomorphology and sediment fills, which produces more complete  
62 reconstructions of palaeofluvial activity in karst settings.

63

64 In karst regions, alluvium is often well-preserved in endokarstic cavities. The most distinctive  
65 endokarstic features are the horizontal tubes that form in the saturated zone: syngenetic and  
66 paragenetic galleries, the latter of which form upward to the water table (e.g. Ford & Williams,  
67 1989; Quinif, 1989). These features correspond to periods of base level stability in the fluvial  
68 system. In contrast, meandering canyons and vadose shafts form in the unsaturated zone, and

69 may be correlated to incision in the adjacent valleys (Audra & Palmer, 2011). The transition  
70 from phreatic to vadose conditions produces keyhole (T-form) features, and the reshaping of  
71 previously enlarged passages and narrow and deep underground canyons during river  
72 entrenchment phases.

73  
74 In limestone karst, cave formation occurs due to the dissolution of bedrock by unsaturated water  
75 containing carbonic acid (from CO<sub>2</sub>) (Palmer, 1991). The maximal denudation rates in the  
76 temperate zone occur in the wetter oceanic regions (even in wet subarctic areas), such as in  
77 Chilean Patagonia (100 mm/ka, Hobléa *et al.*, 2001) or in the Vercors, French subalpine chains  
78 (120-170 mm/ka, Delannoy, 1982), and primarily depend on the amount of precipitation  
79 (Palmer, 1991). Under interglacial and interstadial conditions, forest soils are well-developed,  
80 and these can be an especially aggressive dissolution agent (Ford & Williams, 1989; Quinif,  
81 2006). White (1988) highlighted the existence of thresholds in the development of cave  
82 passages. First, a laminar flow regime produces micro-caves (diameter: 5-10 mm) during an  
83 initiation phase of 3-5 ka. Then, turbulent flow can shape 1-3 m conduits within a few thousand  
84 years during a phase of enlargement. In high alpine mountains, where high precipitation and  
85 acidic forest soils mean that cave development can be especially rapid, wide conduits (from 1  
86 to 10 m) can appear in a few hundred years (Ford & Williams, 1989).

87  
88 The propagation of groundwater through a karst system is largely determined by its structural  
89 framework (Ford & Williams, 1989). In limestone, only planes of penetrable fissures (e.g.  
90 bedding planes, stratification joints, faults) have sufficient permeability. In rocks with greater  
91 fracturation, permeability is higher due to decreased anisotropy (Bazalgette & Petit, 2005). For  
92 example, in folded rocks that have been subjected to tectonic stresses, fissure frequency and  
93 therefore permeability, is generally higher (Ford & Williams, 1989). Fissure frequency also  
94 increases over time, in relation to solvent water infiltration (Gabrovšek *et al.*, 2014) and rock  
95 decompression due to valley entrenchment. These structural controls on subterranean  
96 morphology also explain the existence of caves in non karstified areas: opened faults,  
97 underground collapse structures, or caves shaped in impervious rocks. For example, the Verna  
98 cave (Pyrenees, the biggest cave chamber in France), is mainly situated in Carboniferous  
99 sandstone and shales (Gilli, 2010). In general, geomorphological maps of karstified areas show  
100 parallel horizontal passages, aligned with the main regional fractures (Losson, 2003) and,  
101 sometimes, a gridded cave network of intersecting, fracture-controlled fissures (Palmer, 1991;  
102 Audra & Palmer, 2011). However, fluvial geometry can develop independently of structural

103 controls, such as in the Eastern Paris Basin, where rivers are superimposed on the Mesozoic  
104 strata (Le Roux & Harmand, 1998, 2003).

105

## 106 **1.2. Types of cave sedimentary fill**

107

108 Cave deposits are highly variable in their origin and characteristics, and include allochthonous  
109 and autochthonous sediments which can be broadly categorized as coarse and fine-grained  
110 clastic sediments, and carbonate precipitates. The most common cave formations are the coarse  
111 clastic deposits of the entrance facies. In the glaciated parts of Europe and North America much  
112 of this clastic material is derived from glacial till and deglacial sediments (Granger *et al.*, 2001).  
113 In non-glaciated areas, clastic deposits are the result of bedrock breakdown and decompression  
114 close to the valley sides as well as cryoclastic processes at the cave entrance (Campy, 1982).  
115 Cryoclastic sediments can include palaeontological and/or archaeological remains, such as in  
116 the “Belle-Roche” cave, developed in the Carboniferous limestone of the Amblève valley  
117 (Ardenne massif, E. Belgium; Cordy *et al.*, 1993; Rixhon *et al.*, 2014). There, the archaeo-  
118 palaeotological layers overlie basal Amblève gravels, indicative of a palaeovalley floor  
119 position (Rixhon & Demoulin, 2010). The presence of such coarse sediments, deposited by high  
120 energy flows, generally indicate a period of enhanced fluvial activity in the cave environment  
121 (Ford & Williams, 1989).

122

123 Secondary carbonates are formed by the dissolution of calcium carbonate in the karst bedrock  
124 and its reprecipitation, producing features such as tufa, travertine, and speleothems (Couchoud,  
125 2008). These precipitates develop in association with prevailing environmental conditions, and  
126 reflect changes in water percolation, evaporation and degassing. They can therefore provide  
127 valuable records of palaeoclimate, palaeoecology, and palaeogeomorphology – since tufa and  
128 travertine cap palaeoland surfaces. Moreover, they can be dated by radiocarbon ( $^{14}\text{C}$ ) and  
129 Uranium-series (U-series) methods. Speleothems in particular can provide very high temporal  
130 resolution palaeoclimatic data due to their banded nature. Tufa and travertine (*sensu lato*) are  
131 more complex, and can form in multiple, superimposed horizons or tiered steps of different  
132 ages (Ford & Williams, 1989).

133

## 134 **1.3. Markers of Pleistocene valleys evolution**

135

136 Many studies have thoroughly discussed the relationships between karst terrain and catchment  
137 sediment flux, incision and aggradation (Benito *et al.*, 1998, 2010; Granger & Palmer, 2001;  
138 Jaillet *et al.*, 2004; Mocochain *et al.*, 2009; Audra & Palmer, 2011; Guifang *et al.*, 2011; Calvet  
139 *et al.*, 2015; Columbu *et al.*, 2015). During the Pleistocene, karst evolution was conditioned by  
140 climatically-driven cycles of river incision and aggradation, operating over 41 ka and 100 ka  
141 timescales (Bridgland & Westaway, 2007). In most cases, cave levels formed following  
142 entrenchment of rivers into limestone rocks, lowering the piezometric level. Incision into  
143 preexisting alluvium and the substratum occurred either during warm–cold (e.g. karst of N  
144 France; Antoine, 1994) or cold–warm transitional periods (e.g. British karst; Bridgland &  
145 Westaway, 2007; Lewin & Gibbard, 2010). Aggradation occurred chiefly during cold periods,  
146 characterised by massive deposition of gravel and sand,. Evidence of other cold climate  
147 indicators, such as ice-rafted blocks, ice wedges, and cryoturbation, have also been identified  
148 in karst alluvial sequences. River gravels at the valley bottom (e.g. Antoine *et al.*, 2006) or  
149 terraces (e.g. Bridgland *et al.*, 2009) are sometimes covered by interglacial or interstadial  
150 alluvial silt, soils, peat, and tufa.

151  
152 Evidence of progressive stacking of alluvial sequences indicates the raising of cave level (Audra  
153 & Palmer, 2011), while fill-in-fill terraces imply a succession of lowering and raising of base  
154 and caves levels. At the valley scale, Pleistocene uplift generates tiered terraces provided that  
155 progressive vertical fluvial incision was accompanied by lateral erosion due to channel  
156 migration (Lewin & Gibbard, 2010). In karst areas where only few remnants of strath terraces  
157 are preserved along deeply-incised canyons, only infilled caves can be used to precisely  
158 reconstruct the evolution of Pleistocene valley entrenchment (Audra *et al.*, 2001).

159 In karstic fluvial settings, sediment sources, transportation and deposition characteristics vary  
160 in accordance with Quaternary environmental changes. On the one hand during glacial and  
161 periglacial periods, enhanced sediment mobilization means that clastic sediment can become  
162 trapped in caves and karst depressions (Audra *et al.*, 2001; Audra, Ed, 2010; Rixhon *et al.*,  
163 2014; Calvet *et al.*, 2015). In areas covered by ice-sheets, sedimentation ceases. On the other  
164 hand, during interstadial, interglacial, and postglacial climates, tufa, travertine, and speleothems  
165 generally developed as a result of prolonged valley floor stability (Delannoy, 1997; Frank *et*  
166 *al.*, 2006; Limondin-Lozouet *et al.*, 2006; Couchoud, 2008).

167  
168 Endokarstic alluvial deposits thus have the potential to offer a valuable record of Quaternary  
169 river system evolution. However, fragmentary nature of endokarstic deposits, and their

170 integration with other sedimentary records over different timescales are two key issues that  
171 need to be addressed. Can endokarstic fluvial deposits be reliably integrated with other alluvial  
172 records to produce a model of Quaternary valley evolution? Can we combine records from  
173 fragmentary time slices into the same landscape evolution model (valley terraces, isolated  
174 endokarstic remnants, tiered passages in karst massifs)?

175

176 This paper presents a synthesis of recent research in European karst river systems (where  
177 appropriate, we also refer to well-studied non-European karst settings), developed within the  
178 modern temperate climate zone (Fig.1). It considers multiple spatial scales, from localized cave  
179 deposits to regional palaeoenvironmental reconstructions. It also discusses climatic, glacial,  
180 tectonic, isostatic, and eustatic forcing on karstogenesis (lowered sea level causes rejuvenation  
181 of karst processes, and subsequent raised sea level generates successive cave levels in systems  
182 fluvially linked to coastal locations), as well as the increasing application of dating methods on  
183 alluvial sediments in karst terrains, such as U-series, terrestrial cosmogenic nuclide (TCN) and  
184  $^{14}\text{C}$ . We establish a typology of the relationships between speleogenesis and fluvial  
185 incision/aggradation. Finally, we propose four conceptual models of karstic fluvial  
186 development based on the reviewed literature.

187

188 We examine their Quaternary development which is influenced by periglacial and glacial  
189 processes in mountain settings. In glaciated areas, fluvial discharge would have been directly  
190 linked to glacier mass balance (see 4.3). In periglacial settings, river flow regime would have  
191 been strongly influenced by precipitation and temperature variability.

192

## 193 **2. Dating methods in karstic environments**

194

195 Until the 1980s and 1990s, relative dating techniques (notably palynology and  
196 palaeomagnetism) were the primary methods used to estimate the age of fluvial deposits in karst  
197 terrain (Ford & Williams, 1989). Several numerical dating methods, such as  
198 thermoluminescence (TL, Huxtable and Aitken, 1991), uncalibrated radiocarbon ( $^{14}\text{C}$ , Bastin  
199 & Gewalt, 1986) and Uranium-series (U-series) in caves and river terrace calcrete were also  
200 used (Ambert & Ambert, 1995). Advances in numerical dating methods during the last two  
201 decades have allowed more robust chronologies to be developed (Couchoud, 2008; Richard *et*  
202 *al.*, 2015; Rixhon *et al.*, 2016). Calibrated radiocarbon ages (cal  $^{14}\text{C}$ ), optically stimulated  
203 luminescence (OSL, e. g. Vernet *et al.*, 2008), and electron spin resonance (ESR, e. g. Moreno

204 *et al.*, 2012) techniques have become more widely applied. Terrestrial cosmogenic nuclide  
205 (TCN) dating of karst environments, especially burial dating, has also greatly enhanced the  
206 understanding of complex interactions between karst and fluvial systems (Granger *et al.*, 1997).

207

## 208 **2.1. Numerical methods to date tufa, travertine and fluvial calcrete**

209

210 Secondary carbonates, such as tufa, travertine, calcrete and speleothem, have been widely used  
211 to date landscape change in karst environments, most commonly using U-series methods  
212 ( $^{230}\text{Th}/\text{U}$ ,  $^{231}\text{Pa}/^{238}\text{U}$ ,  $^{234}\text{U}/^{238}\text{U}$ ,  $^{206}\text{Pb}/^{238}\text{U}$ ). At Pierre-la-Treiche, located along the entrenched  
213 Mosel valley into the Bajocian limestones (NE France), U-series ages of speleothems in fossil  
214 caves indicated that their growth was correlated to marine isotope stage (MIS) 6.5, 5.3, 3.3, 3.1,  
215 and 1 (Losson *et al.*, 2006). The U-series ages were used to identify several abrupt warming  
216 phases during MIS 3 - a cold period recorded in the Greenland ice cores and in the Grande Pile  
217 peat record from the Southern Vosges mountains, NE France (Pons-Branchu *et al.*, 2010). U-  
218 series analysis of pedogenic and groundwater calcrete horizons has also been used to constrain  
219 the timing of fluvial aggradation in karst settings such as the Sorbas basin of SE Spain (Candy  
220 *et al.*, 2015) and the limestone Orjen massif, western Montenegro (Adamson *et al.*, 2014),  
221 respectively.

222

223 A chronology based on multiple dating methods allows us to rigorously examine the  
224 relationships between fluvial evolution and karstification, where tiered travertine steps increase  
225 coherently with terrace age, or if there is a more complex terracing history involving cut-and-  
226 fil terraces, for example. A good example is the Tarn valley, near Millau (S France), where the  
227 dating framework has been a matter of debate (Ambert & Ambert, 1995). Based on the  
228 presumed ages of the travertine steps, the rate of incision of the Tarn Canyon was thought to be  
229 very low. However, recent OSL dating as well as palaeoecological and palaeontological  
230 analyses showed that the majority of travertine steps (Peyre) formed during MIS 5e-5b (Vernet  
231 *et al.*, 2008). This indicates that the incision rate in the Tarn valley has reached >30 cm/ka since  
232 the deposition of the ~75 ka-old terrace 3 (MIS 5b-5a), located 25 m above the valley floor.  
233 Secondary carbonate-based chronologies can be used alongside stable oxygen ( $\delta^{18}\text{O}$ ) and  
234 carbon ( $\delta^{13}\text{C}$ ) isotope ratio analysis to provide a record of interglacial climatic changes  
235 (Dabkowski *et al.*, 2011, 2016), such as interglacial tufas in France (e.g. La-Celle-sur-Seine,  
236 Paris Region: MIS 11 and Caours, Somme Basin: MIS 5e) and pedogenic calcretes in Southeast  
237 Spain (Adamson *et al.*, 2015; Gázquez *et al.*, 2016).



238

## 239 **2.2. $^{26}\text{Al}/^{10}\text{Be}$ burial dating of cave-deposited alluvium**

240

241 Burial dating is based on the differential decay of at least two cosmogenic nuclides (Granger  
242 and Muzikar, 2001). Amongst them, the pair  $^{26}\text{Al}/^{10}\text{Be}$  is very well suited because: 1) both  
243 nuclides are produced in quartz, 2) their production ratio is fundamentally independent of  
244 latitude and altitude, and 3) it varies only slightly with depth (Dunai, 2010). Burial dating is  
245 useful in those settings where previously exposed quartz-bearing material (i.e. for  $^{26}\text{Al}/^{10}\text{Be}$ )  
246 becomes shielded from cosmic rays. Two basic assumptions must be fulfilled for a fast and  
247 complete burial (Granger and Muzikar, 2001). First, the time span over which incomplete  
248 shielding occurs is much shorter than the subsequent burial duration. Second, shielded  
249 sediments are buried deeply enough, i.e. in practice  $\geq 30$  m (rock equivalent mass), implying an  
250 insignificant production through muons at depth. We refer to the comprehensive works of  
251 Granger and Muzikar (2001), Dunai (2010) and Granger (2014) for further information about  
252 the basic principles of burial dating, including mathematical developments.

253

254 In the fluvio-karstic context, the burial event is achieved when river sediments, formerly  
255 exposed to cosmic rays at the Earth surface during hillslope denudation and fluvial transport,  
256 are washed into an underground system. The two aforementioned prerequisites are frequently  
257 met for in-cave deposited alluvium; the study of Granger *et al.* (2001) in Mammoth cave (i.e.  
258 the longest cave system known in the world, developed in Mississippian limestones in the  
259 Kentucky Appalachian Plateau) is one of the first successful applications of burial dating to  
260 such sediments. Since then, quartz-bearing material deposited into different multi-level cave  
261 systems by streams or rivers flowing into the sub-surface has been dated in a range of  
262 tectonically-active (e.g. Stock *et al.*, 2004) or moderately-uplifted (e.g. Anthony and Granger,  
263 2007) settings. Inferring long-term river incision rates in these environments relies on the key  
264 assumption that the alluvium deposited in a horizontal, hydrologically abandoned, phreatic tube  
265 represents the last time the passage was at the local water table (Anthony and Granger, 2007).  
266 The selection of suitable sampling sites should ensure that abandoned and alluvium-filled  
267 phreatic tubes were not contaminated by any reworked material from an older (or younger)  
268 depositional episode (Dunai, 2010). It is therefore recommended to sample sediment layers  
269 displaying fluvial features or structures (Anthony and Granger, 2007) and/or where other  
270 material allows a cross-check with an independent dating method (e.g. U-series dating of a  
271 speleothem/flowstone sealing the fluvial sequence; Stock *et al.*, 2005).

272

273 In Europe, this approach, sometimes used in combination with paleomagnetism and U-series  
274 dating, was mostly applied to cave systems of mountainous environments: both in the Eastern  
275 (Wagner *et al.*, 2010; Häuselmann *et al.*, 2015) and the Western Alps (Häuselmann *et al.*, 2007;  
276 Hobléa *et al.*, 2011), and in the Pyrenees (Calvet *et al.*, 2015). Three case studies exemplify the  
277 value of burial dating of in-cave deposited alluvium to unravel long-term landscape evolution  
278 in diverse karstic environments (Fig. 2). First, the Têt valley (Eastern Pyrennées, France) shows  
279 nine karst levels, between 1400 to 400 m a.s.l., along its epigenetic fluvial gorge cut into the  
280 Devonian limestones of Villefranche de Conflent, with caves filled by sand and siliceous  
281 pebbles (Calvet *et al.*, 2015). Level 5 was dated from the lower Pliocene and level 3 from the  
282 Early Pleistocene, allowing an estimate of an incision rate of ~52 m/Ma, with a clear  
283 acceleration to 90 m/Ma for the last Ma. Level 3 is clearly linked to the upper terrace of the Têt  
284 valley and all the lower cave levels and sublevels strongly correlate to the younger terrace  
285 levels. Second, burial ages from different speleogenetic levels of the Siebenhengste-Hohgant  
286 cave system (Aare catchment, Switzerland) revealed a remarkable increase of glacial valley  
287 lowering since the beginning of the Middle Pleistocene, which substantially postdates the onset  
288 of glaciation in this region (Häuselmann *et al.*, 2007). This might be related to a considerable  
289 lowering of the equilibrium line altitude and the transgression of threshold conditions beyond  
290 which increase in glacial downcutting rates becomes nonlinear (Brocklehurst and Whipple,  
291 2004). Third, burial ages coupled with magnetostratigraphy in multi-level cave systems along  
292 the Ardèche valley indicated a stepwise karst genesis during the Plio-Pleistocene, consistent  
293 with the *per ascensum* model of Mocochain *et al.* (2009), after the Messinian salinity crisis  
294 (Tassy *et al.*, 2013) especially, during the rise of sea level in the Lower Pliocene. These data  
295 also highlighted an uplift rate of ~30 mm/ka since 1.8 Ma in the lower Ardèche area.

296

### 297 **2.3. Strengths and weaknesses of dating methods**

298

299 Each numerical dating technique has an upper age limit (e.g. U-series: c. 350 ka; OSL: c. 150-  
300 200 ka; <sup>26</sup>Al/<sup>10</sup>Be burial dating: c. 5.5 Ma) and associated analytical uncertainties. Ages  
301 obtained from adjacent karstic areas, or even within the same valley, can vary considerably. For  
302 example, in the Sierra of Atapuerca and the Arlanzón Valley (Moreno *et al.*, 2012) and in the  
303 upper Mosel catchment (Harmand & Cordier, 2012), TL, IRSL, ESR and U-series ages  
304 provided divergent results. In such instances, different ages may reliably represent spatial  
305 variations in uplift rates, river incision and karstification. However, it must be borne in mind

306 that these dating methods provide age information about different processes of landscape  
307 evolution. Whereas burial ages give constraints about the last time the phreatic passage was at  
308 the local water table, U-series ages date the timing of calcite formation and thereby provide  
309 minimum ages of sediment deposition. A clear understanding of the chronostratigraphic  
310 framework is therefore essential. Detailed geochronological studies, using multiple dating  
311 methods, are required to reliably quantify rates of incision and karstification.

312

### 313 **3. Approaches for examining drainage evolution in karstic terrains**

314

315 The relationship between valley incision and karstification are summarized in Figure 3. Much  
316 research has focused on the impacts of valley entrenchment on karst development, which can  
317 in turn provide important insights into fluvial evolution. However, karst development can occur  
318 independently of valley evolution, especially when dealing with the ghost-rock process (i.e.  
319 rock transformation by self-volume chemical dissolution; Vergari & Quinif, 1997) or hypogene  
320 karstification (i.e. dissolution and crystallization along ascending, often hydrothermal, flows;  
321 Hill, 1987). A number of studies have highlighted the influence of karst terrain on valley  
322 incision (Figure 3).

323

324 Analysis of the relationship between fluvial evolution and karstification requires a multiscale  
325 approach, evolving from the valley bottom to the karst, and from the karst to the valley. This  
326 review proposes a typology of relationships between karst and valley, depending on  
327 morphostructural framework, lithology, base level change, and climatic fluctuations  
328 (emphasizing the role of glaciers).

329

#### 330 **3.1. From the valley bottom to the karst: relationships between karst cave level and valley** 331 **base level**

332

333 Many studies have highlighted the relationships between base level or cave level and the  
334 regional evolution of river systems controlled by climatic, tectonic and/or eustatic forcing  
335 (Ambert & Ambert, 1995; Jaillet, 2000; Audra *et al.*, 2001; Losson, 2003; Harmand *et al.*, 2004;  
336 Wang *et al.*, 2004; Mocochain *et al.*, 2009; Guifang *et al.*, 2011; Ortega *et al.*, 2013; Tassy *et*  
337 *al.*, 2013). As a result, it is well-established that karstic levels can provide valuable altitudinal  
338 markers, or ‘dip sticks’ for river incision. This is especially effective in mountain massifs where

339 local relief can exceed several kilometers, and multiple cave levels exist, therefore providing  
340 long-term records of fluvial evolution since the Plio-Pleistocene.

341  
342 Karst plays a major role in the formation and preservation of the fluvial sedimentary record.  
343 Where alluvial sediments accumulated in karst depressions, they became more immune to  
344 subsequent erosion and reworking (Delannoy, 1997; Audra *et al.*, 2001). Ancient alluvium is  
345 reported to have been preserved within karst settings since the Early Pleistocene (Wagner *et al.*,  
346 2010; Adamson *et al.*, 2014; 2016); the Neogene (Hobléa *et al.*, 2011; Calvet *et al.*, 2015), the  
347 Paleogene (Bruxelles *et al.*, 2013) and even the Mesozoic (Vergari & Quinif, 1997), Palaeozoic  
348 (Osborne, 2007) and Precambrian (Buffard & Fischer, 1993). The excellent preservation  
349 potential of these records means that they are valuable archives of landscape change. This is  
350 especially the case where palaeovalleys or alluvial terraces are not well-preserved at the surface,  
351 when karstic cavities are disconnected from adjacent valleys, due to headward erosion  
352 (Enjalbert, 1967, *in* Nicod, 2010); or when there have been changes to drainage patterns  
353 (Adamson *et al.*, 2014). However, correlations between cave deposits and valley fills at the  
354 surface are sometimes difficult when karstic sediments are present only in isolated fragments,  
355 due to erosion and reworking of the exposed sediments (Quinif & Maire, 1998).

### 356 357 **3.2. From the karst to the valley: Base level controls on the geometrical organization of** 358 **karst drainage networks**

359  
360 Assuming that initial cave development occurs along the water table, Ford and Ewers (1978)  
361 proposed a conceptual framework called the “four-state model”. In this model, different types  
362 of caves evolve depending on increasing fissure frequency through time: 1) bathyphreatic  
363 caves, with a few deep phreatic loops (Figure 2B.a, c, d); 2) phreatic caves with multiple and  
364 shallower loops (Audra & Palmer, 2011); 3) caves with a mixture of phreatic and water table-  
365 levelled components; and 4) an idealised water table cave without loops, formed as a result of  
366 high fissure frequency. The four-state model has been reinterpreted by Häuselmann (2002),  
367 Audra & Palmer (2011) and Gabrovšek *et al.* (2014) who pointed out two main controls in  
368 relation to valley incision: 1) The recharge control occurs in dammed aquifers, when recharge  
369 is fairly regular. Thus, the main endokarstic drain is established at the water table at the same  
370 altitude as the valley bottom (Figure 2B.b). When an irregular recharge occurs, looping tubes  
371 develop throughout the epiphreatic zone (Figure 2B.a). 2) The base-level control corresponds  
372 to the development of perched cave levels. Base level lowering is common in most temperate

373 climate karstic areas, especially mountainous regions, due to uplift of the continental crust and  
374 associated river incision (Figure 2A, Fig. 2B.c). In contrast, base-level rise produces flooded  
375 cave levels and Vauclusian springs, when water ascends (Figure 2B.c). Deep-phreatic cave  
376 systems, for instance, are located around the Mediterranean Sea, as a result of the Messinian  
377 marine regression and near instantaneous Pliocene flooding (Mocochain *et al.*, 2009).

378

### 379 **3.3. A multi-scale approach**

380

381 To effectively capture the complexity of karst evolution, and securely identify the relationships  
382 between fluvial activity and karstification, multi-scale analysis should be used to combine  
383 large-scale studies of karstified massifs and entrenched valleys, and local-scale analysis of  
384 individual karst drains and sediment fills. In valleys entrenched up to several hundred meters  
385 deep, numerous studies (Webb *et al.*, 1992; Audra *et al.*, 2001; Losson *et al.*, 2006; Guifang *et*  
386 *al.*, 2011; Rixhon *et al.*, 2014) have highlighted the altitudinal relationship between karstic  
387 passages and stepped terraces (Figure 2A). At the valley scale, establishing the elevation of  
388 alluvial terraces and karstic drains to within a few metres is sufficient for reliable  
389 geomorphological reconstructions. For example, in the Sierra de Atapuerca and the Arlanzón  
390 valley (Iberian Chain, Eastern Burgos, Spain), geomorphological analysis was combined with  
391 archaeology, palaeomagnetism, TL, IRSL, U-series and ESR dating to develop a  
392 chronostratigraphical framework of fluvial incision and speleogenesis of karst caves during the  
393 Lower and Middle Pleistocene (Moreno *et al.*, 2012; Ortega *et al.*, 2013).

394

395 At even larger spatial scales, across the Mediterranean basin for example, karstic and  
396 palaeovalley features suggest a common regional pattern of geomorphological evolution. At the  
397 Mediterranean coast, such as the South-East of France, Messinian canyons and Pliocene rias,  
398 among other features, demonstrate that sea level change has had a major influence on  
399 karstification (Audra *et al.*, 2004). Late Miocene base-level fall was followed by rising base-  
400 level in the Pliocene, which flooded lower endokarstic levels, and karst waters discharged as  
401 Vauclusian springs. In this system, higher elevation karst horizons are more recent forms, as  
402 indicated by *per ascensum* speleogenesis.

403

404 At smaller spatial scales, in individual caves or valleys, high-resolution analysis is essential  
405 when caves are disconnected from neighbouring valleys – due to erosion of the limestone valley  
406 sides or of terrace remains. For example, in the Pierre-Saint-Martin cave, Pleistocene deposits

407 of the Aranzadi gallery recorded a succession of depositional and entrenchment phases (Quinif  
408 & Maire, 1998). Three groups of speleothems situated between the detrital units highlighted the  
409 succession of several interglacial or interstadial stages allowing the precipitation of carbonate.  
410 U-series dating showed that speleothem growth occurred during MIS 9, 7 and early MIS 6. In  
411 the Têt river basin, recent research has provided precise correlations between aggradation and  
412 incision phases in each glacial cycle (Hez *et al.*, 2015; see section 5 for discussion).

413

#### 414 **4. A typology of the relationship between fluvial evolution and karstification**

415

416 As outlined above, fluvial incision and karstification in limestones or evaporite rocks are driven  
417 by a number of factors. The most central are: eustasy, isostasy, climate and tectonics. Here we  
418 discuss the relationships between valley evolution and speleogenesis using examples from  
419 across Europe, as well as key studies in Australia, North America, and the Tibetan Plateau. Four  
420 models of valley evolution and karstification are proposed.

421

#### 422 **4.1. Karstification in association with base and cave level lowering**

423

424 A number of karst systems have horizontal tubes and vertical conduits which reflect stability  
425 and incision in the neighbouring valleys, respectively. These valleys often contain stepped  
426 alluvial terraces associated with aggradation/incision cycles. Generally, epigenetic  
427 speleogenesis of limestone massifs and the succession of valley incision and aggradation are  
428 largely associated with strong isostatic or tectonic uplift. Climatic forcings have also played a  
429 key role, especially at the onset of the Quaternary, and during the Mid-Pleistocene Revolution  
430 at the onset of the 100 ka Milankovitch cycles (Bridgland *et al.*, 2009). Four types of  
431 geomorphological evolution are distinguished in the following discussion, based on the relief  
432 energy/topography of the karstified region.

433

#### 434 **4.1.1. Karstification in low elevation and very stable cratonic area**

435

436 The Devonian limestone region of Buchan (South-East Australia) is a valuable example of slow,  
437 long-term incision and speleogenesis. Three fluvial terraces and epiphreatic cave levels have  
438 developed below a height of 30 m above the adjacent river (Webb *et al.*, 1992).  
439 Geomorphological evidence and palaeomagnetic dating indicate that these formed before 780  
440 ka, giving a maximum incision rate of 38.5 mm/ka. The Buchan area has experienced only 4-5

441 m incision over the last 40 Ma (i.e. 0.1–0.125 mm/ka), 2-3 m of this has occurred over the last  
442 730 ka (i.e. 2.7–4.1 mm/ka).

443

#### 444 **4.1.2. Karstification on low altitude plateaus (<500 m a.s.l.)**

445

##### 446 **4.1.2.1. General cases**

447

448 There are many examples of epigenetic speleogenesis and fluvial incision as a result of  
449 moderate (up to 10 mm/ka) uplift in cratonic areas, sedimentary basins, and low-altitude (<500  
450 m-a.s.l.) basement plateaus, such as in the Paris, Aquitaine basins (Bridgland *et al.*, 2009; see  
451 *in* Audra, Ed., 2010) or British karst (Waltham *et al.*, 1997). In North America, the karst  
452 evolution of the Kentucky Appalachian Plateau has been dated in detail using TCN ages  
453 (Granger *et al.*, 2001). These karstic areas broadly correspond to one of two morphostructural  
454 settings. 1) Extended horizontal or monoclinical strata of Palaeozoic age (e.g. the Kentucky  
455 Plateau, USA: Granger *et al.*, 2001), Mesozoic or Cenozoic karstified rocks (e.g. in the plateaus  
456 of the Eastern Paris Basin, France; Jaillet, 2000; Losson, 2003; Devos *et al.*, 2007). 2) Folded  
457 strata in Alpine or older (e.g. Appalachian) structures. In most cases the caves are located in  
458 narrow outcrops of limestone, such as the Devonian and Carboniferous rocks of the Ardenne  
459 massif, Belgium (Quinif, 1999, 2006).

460

461 There have been several studies of Pleistocene sedimentary sequences from caves and river  
462 terraces formed on low-level plateaus (Losson, 2003; Jaillet *et al.*, 2004). These studies show  
463 that Pleistocene incision rates were low, and reached up to 100 mm/ka in the Mosel catchment  
464 (Harmand and Cordier, 2012). On low-elevation karst plateau, there is evidence for Quaternary  
465 rejuvenation of older palaeo-karsts or crypto-karsts, such as the Belgian Ardenne, Eastern Paris  
466 Basin, and Quercy plateaus (Bruxelles *et al.*, 2013; Vergari and Quinif, 1997; Harmand *et al.*,  
467 2004). At Poissons (Eastern Paris Basin, France), Pleistocene incision of the upper Marne  
468 reached 42 mm/ka to 58 mm/ka, and extended below the base of the palaeokarstic wells, which  
469 were filled with continental Infra-Cretaceous (Wealdian) ferruginous deposits (Harmand *et al.*,  
470 2004). However, the presence of Late Pleistocene fauna and MIS 6 speleothems in the sediment  
471 fill (Jaillet, 2000) was indicative of a Quaternary karstification of the older palaeo-karsts.

472

##### 473 **4.1.2.2. The relations between rivers, aquifers and karst in the Eastern Paris basin**

474

475 In the Eastern Paris Basin, epigenetic speleogenesis and fluvial incision is linked to the  
476 structural framework of the basin and entrenchment of the main valley into the alternating marl  
477 and limestone strata (Losson, 2003; Devos *et al.*, 2009, 2015). The main feature is the position  
478 of the river with regard to the water table. Four situations can be distinguished (Figure 4A). 1)  
479 When perched rivers are entrenched into limestone above the saturated zone, infiltration occurs  
480 into and under the valley from local or allochthonous flows (Jaillet, 2000; Losson, 2003; Devos  
481 *et al.*, 2009, 2015; Figure 4A level a). 2) When the surface river channel is in contact with the  
482 water table of the saturated zone, the lack of hydraulic gradient induces a ghost rock process  
483 around the fractures of the valley floor (Quinif, 2010, Devos *et al.*, 2011; Figure.4A level b). In  
484 contrast, lowering of the piezometric level, due to fluvial incision, causes the discharge of  
485 residual deposits of the ghost rocks and the creation of conduits in the epiphreatic zone. 3)  
486 When the surface river channel is strongly entrenched into the limestone substratum, and drains  
487 the flooded karst zone, a thin piezometric horizon develops (Figure 4A level c). 4) If fluvial  
488 incision occurs in the marls or clays situated below the saturated zone, the perched karstified  
489 zone is disconnected from the river (Figure 4A level d) and the flooded zone drains into low  
490 flow springs (Devos *et al.*, 2015). However, as shown in Figure 4B, it is important to remember  
491 that the faulted tectonic basement can produce structural and aquifer compartments which  
492 control the hydraulic gradient between aquifers and rivers (Devos *et al.*, 2007). This can have  
493 major impacts on the hydrological and geomorphological connectivity, between karst and  
494 subaerial fluvial drainage networks.

495

#### 496 **4.1.3. Relationships between fluvial incision/aggradation and karstification on high** 497 **altitude plateaus and low mountain ranges (500 – 2,000 a.s.l.)**

498

499 In low mountain ranges and high plateaus, a moderate uplift rate (up to 100-200 mm/ka)  
500 commonly causes deep fluvial incision and epigenetic speleogenesis in thick limestone strata.  
501 On some high plateaus, geomorphological processes have continuously shaped the landscape  
502 since the Neogene. In the Southern part of the Causse of Larzac, four stages of speleogenesis  
503 were identified from the Middle Miocene until the Pliocene (Camus, 1997, 2010). Even during  
504 the Pleistocene, there is evidence of phases of incision and karstification in many regions, such  
505 as the Sierra de Atapuerca and the Arlanzón valley (Moreno *et al.*, 2012; Ortega *et al.*, 2013),  
506 the Languedocian plateaus (Audra *et al.*, 2001) or the Swabian Alb (Abel *et al.*, 2002). These  
507 speleogenetic phases occurred in response to base-level and cave-level lowering, due to tectonic  
508 uplift and glacially-driven sea level change. During Pleistocene glacial stages, sea level fell by



509 up to 140 m below modern levels (Rohling *et al.*, 2009). In some settings, such as the Arlanzón  
510 and Ardèche valleys, incision has reached over 100 m deep since the Lower Pleistocene. The  
511 number of terrace levels varies between the narrow middle Ardèche valley (4) and the wide  
512 Arlanzón valley (14), but the karstified massifs exhibit only 2 or 3 cave levels, respectively  
513 (Audra *et al.*, 2001; Moreno *et al.*, 2012; Ortega *et al.*, 2013).

514

#### 515 **4.1.4. Long-term records of fluvial incision and karstification in high mountain regions** 516 **(>2,000 m a.s.l.)**

517

518 Many high altitude limestone mountains contain horizontal cave networks at elevations  
519 exceeding 2,000 m a.s.l. (Feichtnerschacht, Austrian Alps: 2,000 m; French subalpine chains:  
520 2,300 m; Dolomites, northeastern Italy: 2,775 m; Siebenhengste-Hohgant-Höhle, Berner  
521 Oberland, Switzerland >2,000 m; Häuselmann and Granger, 2005; Audra *et al.*, 2007; Wagner  
522 *et al.*, 2010, Hoblea *et al.*, 2011; Figure 5A). Many of these mountains contain thick horizons  
523 of karstified rock that extend vertically for up to 1 km, and are characterized by cave to rock  
524 ratios as high as 1.3 m<sup>3</sup> per 1000 m<sup>3</sup>. Some high mountains also contain long karstic cavities  
525 (up to 90 km in the Granier massif, Grande Chartreuse, France, Hoblea *et al.*, 2011) and many  
526 cave levels (9 in the Têt catchment; 14 in the Siebenhengste; Calvet *et al.*, 2015; Häuselmann,  
527 2002). These stacked caves indicate numerous speleogenetic phases and strong uplift trends.  
528 Where these endokarstic galleries contain alluvial sedimentary sequences, they have the  
529 potential to record long-term fluvial evolution. Key examples include the European Alps  
530 (Styrian Alps: Wagner *et al.*, 2010; Grande Chartreuse massif: Hoblea *et al.* 2011), the Alpi  
531 Apuane, Italy (Piccini *et al.*, 2011), the Sierra Nevada, California (Stock *et al.*, 2004, 2005),  
532 and the Hengduan Shan, Tibet (McPhillips *et al.*, 2016).

533

534 In the Alps and Pyrenees, TCN burial dating of sediment infills from the highest cave levels  
535 frequently yielded Pliocene ages (Häuselmann and Granger, 2005; Wagner *et al.*, 2010; Hoblea  
536 *et al.*, 2011; Calvet *et al.*, 2015). The same method, based on the <sup>10</sup>Be and <sup>21</sup>Ne isotope pair,  
537 revealed a Lower Miocene karstification age at the Southeast margin of the Tibetan Plateau at  
538 the First Bend (McPhillips *et al.*, 2016). Valley incision and karstification continued during the  
539 Quaternary period in European karst regions (Häuselmann and Granger, 2005; Wagner *et al.*,  
540 2010; Calvet *et al.*, 2015), and in China (Qinling: Wang *et al.*, 2004; Northwestern Hunan:  
541 Guifang *et al.*, 2011; Guizhou plateau: Liu *et al.*, 2013).

542

543 Many high altitude karstified massifs, including the limestone mountains of Europe (e.g.  
544 Hughes *et al.*, 2010) and North America (Palmer and Palmer, 1993), were glaciated during  
545 Pleistocene cold stages, including MIS 12, 6, and the Younger Dryas. As a result, they evolved  
546 into a distinctive ‘glaciokarst’ landscape (See section 4.3).

547

#### 548 **4.2. Karstification in association with rising base and cave level**

549

550 The *per ascensum* model of speleogenesis is initiated by eustasy and climatically-driven  
551 aggradation and subsidence (Audra *et al.*, 2001; Figure 5B). The influence of eustatic base level  
552 does not typically extend more than 200 km inland (Antoine *et al.*, 2000). In Europe, one of the  
553 most significant examples of rising base level and its impacts on terrestrial landscape change is  
554 the Pliocene transgression after the Messinian regression of the Mediterranean basin (e.g.  
555 Clauzon, 1978; Audra *et al.*, 2004).

556

557 The Languedocian plateaus, incised by the Lower Ardèche canyon (at Saint-Remèze), present  
558 a record of rising base and cave level since the Messinian. TCN dating combined with  
559 magnetostratigraphy revealed that, following an early phase of karstification during the  
560 Messinian regression, subsequent phases of speleogenesis took place during marine and  
561 continental aggradation in the Pliocene rias (Mocochain *et al.*, 2009; Tassy *et al.*, 2013, 2014).  
562 Rising base level caused flooding of the lower cave levels, which discharged as Vaclousian  
563 springs. Pleistocene valley incision led to the progressive draining of horizons situated above  
564 base level and the reactivation of caves at the same altitude as the river.

565

566 Other cases of base and cave level fluctuations follow a similar evolutionary model (Bruthans  
567 and Zeman, 2003; Audra and Palmer, 2011). Several cases of *per ascensum* speleogenesis by  
568 fluvial (or glacial) aggradation occur in Europe, including Podtraťová jeskyně in the Moravian  
569 karst (Czech Republic, Bruthans and Zeman, 2003) and in the Devoluy mountains, France  
570 (Audra & Palmer, 2011). In the Devoluy chain, the Pleistocene glacial, lacustrine, and  
571 glaciofluvial sediment fill increased the elevation of the Gillardes karst springs, and caused the  
572 300 m high chimney shaft at Puits de Bans to overflow.

573

#### 574 **4.3. Pleistocene incision and karstification in association with glaciation**

575

576 Broadly, there are three mechanisms through which Pleistocene glacial activity influenced karst  
577 areas. First, in non-glaciated mountains or plateaus areas, incision and karstification were  
578 indirectly conditioned by glacial activity, such as the Kentucky Appalachian Plateau (Palmer  
579 and Palmer, 1993). Second, in glaciated mountain regions, such as parts of the Dinaric Alps in  
580 Montenegro (Hughes *et al.*, 2010; 2011; Adamson *et al.*, 2014), and the Pindus mountains in  
581 Greece (Hughes *et al.*, 2006; Woodward *et al.*, 2008), fluvial evolution and karstification were  
582 directly influenced by glaciers. Third, some karst areas were covered by ice sheets up to 3 km  
583 thick that developed across much of Northern Eurasia (Eurasian Ice Sheet) and North America  
584 (Laurentide Ice Sheet) during Pleistocene glacial phases. The erosional effects of the ice sheets  
585 on karst and non-karst landforms and deglacial speleogenesis, are beyond the scope of this  
586 paper, which concentrates on karst geomorphology south of the major ice-sheets, and  
587 downstream of ice caps and valley glaciers (mechanisms one and two outlined above).

588

#### 589 **4.3.1. Indirect impacts of glaciation: the Appalachian plateau of Kentucky, USA**

590

591 The Kentucky Appalachian Plateau (c. 2,000 m a.s.l.) is a vast karstified area that contains an  
592 extensive sinkhole plain (Pennyroyal Plateau) and the Mammoth Cave Plateau where the  
593 famous cave provides a well-preserved example of the indirect influence of glaciers on Plio-  
594 Quaternary morphologic evolution (Palmer and Palmer, 1993). TCN ( $^{26}\text{Al}$  and  $^{10}\text{Be}$ ) dating of  
595 sediments in the five levels of Mammoth Cave, as well as vertical vadose passages, is in  
596 accordance with the timing of Pliocene and Pleistocene glaciations of North America (Granger  
597 *et al.*, 2001). Major aggradational phases occurred at c. 3.2, 2.3 and 0.8 Ma, when large volumes  
598 of sediment would have been produced by the ice sheet and delivered downstream via meltwater  
599 channels. A major incision phase occurred at c. 1.39 Ma in relation to a drainage change towards  
600 the Mississippi catchment when the Ohio river formed along the Southern North-American ice-  
601 sheet margin.

602

#### 603 **4.3.2. Direct impacts of glaciation: Glaciated limestone mountains: examples from the** 604 **Dinaric Alps**

605

606 Limestone mountains that were glaciated by ice caps or valley glaciers during Pleistocene cold  
607 stages, such as the Dinaric Alps, are characterized by a distinctive ‘glaciokarst’ terrain, which  
608 displays features including limestone pavements and bare bedrock surfaces. The presence of  
609 glaciers in karst environments can have major impacts on glaciofluvial drainage pathways, and

610 subsequent karst drainage evolution. On the Orjen massif in western Montenegro, a large ice  
611 cap developed during the Pleistocene (MIS 12, 6, 5d-2 and the Younger Dryas, Hughes *et al.*,  
612 2010). The configuration of the Orjen massif, with its high altitude (c. 1,800 m a.s.l.) ice  
613 accumulation zone, and surrounding depocentres (such as valleys, poljes and dolines), meant  
614 that during the major ice advance of MIS 12, ice extended over the plateau, and likely plugged  
615 the surface of karst depressions and conduits. Meltwater was delivered directly downstream  
616 and largely flowed at the land surface. This is evidenced by the presence of large volumes of  
617 glaciofluvial sediments that have been deposited and preserved in large poljes, as terraced  
618 valley fills, and as alluvial fans at the margins of the plateau (Adamson *et al.*, 2014; 2016a).  
619 One of these alluvial fans, the Lipci fan, extends offshore into the Bay of Kotor. It was deposited  
620 subaerially at the southern margins of the Orjen massif during the major glacial phase of MIS  
621 12, when sea level in this part of the Mediterranean was up to 140 m lower than present, and  
622 the Bay of Kotor was exposed subaerially (Adamson *et al.*, 2016b). U-series ages of the alluvial  
623 deposits at Orjen are consistent with the timing of glacial activity (Hughes *et al.*, 2010). During  
624 subsequent cold stages (MIS 6, 5d-2, and the Younger Dryas), the ice cap did not advance  
625 beyond the plateau. During these periods, large areas of karst were exposed on the plateau, and  
626 meltwater was channeled into subterranean cavities (Adamson *et al.*, 2014). There is only  
627 limited evidence of post-MIS 12 alluvium preserved at the surface of the Orjen massif, and  
628 incision into the sediment fills is negligible. As a consequence, the oldest (Middle Pleistocene)  
629 part of the alluvial record is exceptionally well-preserved, but the youngest archives are not  
630 accessible at the surface. The interactions between glacial activity, karst terrain, and fluvial  
631 pathways, can therefore be a major control on the Quaternary sedimentary record in such  
632 glaciated regions (Stepišnik *et al.*, 2009; Adamson *et al.*, 2014).

633

#### 634 **4.4. The particular case of karstified evaporites**

635

636 In evaporite rocks, karst systems are sparser and tend to be restricted to relatively drier climate  
637 regions due to the restricted availability of moisture. However, in such environments the  
638 preservation potential of karst systems is much higher. In some regions of evaporitic bedrock,  
639 most commonly gypsum, climate forcing in uplifting areas generates cave levels associated  
640 with patterns of river incision and aggradation. In the Northern Apennines, Italy, especially in  
641 the region of Emilia Romagna, the Re Tiberio cave system is hosted in Messinian gypsum  
642 (Columbu *et al.*, 2015). Gypsum is much more soluble than limestone, and cave levels form  
643 very rapidly.

644 Two significant examples of karstified evaporites also exist in Spain, in the Sorbas basin,  
645 Southeastern Spain, and in the Gállego valley, in the central Ebro Basin, with cave levels and  
646 subsidence areas respectively (Calaforra and Pulido-Bosch, 2003).

647

#### 648 **4.4.1. Cave levels in karstified evaporites**

649

650 The Sorbas basin, Southeast Spain, contains an interstratal karst system formed within  
651 intercalated Messinian gypsum and marls (Calaforra & Pulido-Bosch, 2003; Figure 6A). At  
652 first, the gypsum karst evolved under phreatic conditions during the early Pleistocene, enabling  
653 the formation of small conduits. Subsequently, mechanical erosion occurred under vadose  
654 conditions. Increased incision, as a consequence of rapid Plio-Pleistocene uplift (>80-160  
655 mm/ka; Mather, 2000) allowed an eastward capture of the Upper Aguas river system at c. 70  
656 ka (based on U series dating of river terrace calcretes, Candy *et al.*, 2005, Harvey *et al.*, 2014).  
657 Dated pre-capture terraces represent the former southern drainage system of the Rio Aguas,  
658 prior to the river capture event, enabling incision rates to be calculated (Stokes *et al.*, 2002). In  
659 fact, the capture leads to a 10 fold increase in incision rates, driven by the ~90m base level drop  
660 that it initiated (Stokes *et al.*, 2002). This incision led to the development of further cave levels.  
661 Karst tributaries that were connected to the Aguas channel at the surface, were protected from  
662 enhanced incision due to the development of the cave network (Mather 2000). Headward  
663 incision in the Upper Aguas catchment induced a lowering of the piezometric level in the Sorbas  
664 basin. Subterranean erosion processes, largely concentrated into the marl strata, occurred under  
665 vadose conditions (Calaforra & Pulido-Bosch, 2003), and these processes continue at the  
666 present day.

667

#### 668 **4.4.2. Subsidence in evaporite rock areas**

669

670 Bruthans and Zeman (2003) identified a suit of features typical of salt karst terrain, including  
671 broad and low caves shaped by subterranean meandering streams, and the development of large  
672 subterranean alluvial fans, due to the high solubility of salt (NaCl). Apart from these forms, a  
673 key feature of evaporite karst (e.g. gypsum karst) is the incomplete record of valley evolution  
674 due to high solubility and enhanced dissolution and subsidence. A number of examples exist  
675 worldwide, most notably in Spain (Benito *et al.*, 1998, 2010; Figure 6B). In the Gállego valley,  
676 in the central Ebro Basin, Northern Zaragoza, 12 stepped terraces (2-5 m thick) were mapped  
677 upstream of Zuera. Downstream, the complex of alluvial formations is over 100 m thick. This

678 downstream thickening of the alluvial formations, as well as multi-scale karstic depressions and  
679 syn- and post-sedimentary deformations, such as collapses, reverse faults, and marl-clay  
680 diapiric structures, reflect the dissolution of Cenozoic evaporitic bedrock. Palaeomagnetic and  
681 OSL dating revealed two main periods of subsidence and associated alluvial aggradation: the  
682 first (represented by terraces T2, T3, and T4) began in the Early Pleistocene (Benito *et al.*,  
683 1998). The second occurred during MIS 6, primarily when glaciers were present in the  
684 Pyrenees. A later phase also occurred during the Warthe Advance, a later part of MIS 6 (155-  
685 140 ka), as a result of high discharge delivered by the upper catchment of the Gállego River  
686 (Benito *et al.*, 2010).

687  
688 In the Eastern Cinca and Segre catchments of the Ebro Basin, Lucha *et al.* (2012) identified a  
689 phase of dissolution subsidence and halokinetic uplift along the evaporitic core of the  
690 Barbastro–Balaguer Anticline. Eight of the nine fluvial terraces were affected by dissolution-  
691 induced synsedimentary subsidence, by dissolution-induced post-sedimentary subsidence, or  
692 by deformation due to salt flow, especially the upper Pleistocene terrace 4 of the Cinca River.  
693 OSL ages obtained in the alluvial sediments of this backtilted terrace indicated a minimum  
694 uplift rate of 0.3 mm/a (Lucha *et al.*, 2012). Moreover, deposits of the highest terrace levels  
695 reach over 100 m thickness in the Segre catchment, in basins generated by dissolution-induced  
696 synsedimentary subsidence.

697

## 698 **5. Discussion**

699

### 700 **5.1. Variability of incision rates in karst fluvial systems**

701

702 Based on chronological evidence from karstic fluvial sedimentary fills and secondary carbonate  
703 forms, such as travertine and calcrete, long-term regional incision rates can be securely  
704 constrained. In fact, numerical dating highlights the variability in space and time of river  
705 incision rates. Incision rates are highest in high mountains (>2,000 m a.s.l.), exceeding 100  
706 mm/ka in the Alps (Hobléa *et al.*, 2011; Häuselmann & Granger, 2005; Wagner *et al.*, 2010) or  
707 in China (especially on the southeast margin of the Tibetan Plateau, McPhillips *et al.*, 2016).  
708 Incision rates are lower (<100 mm/ka) in the plateaus and low mountain range areas (200-2,000  
709 m a.s.l.), such as the Eastern Paris Basin (Harmand & Cordier, 2012), the Languedocian  
710 plateaus (Ambert & Ambert, 1995; Camus, 1997; Audra *et al.*, 2001), the Duero basin (Moreno  
711 *et al.*, 2012; Ortega *et al.*, 2013), Swabian Alps (Abel *et al.*, 2002), or the Eastern Pyrenees

712 (Calvet *et al.*, 2015). The lowest incision rates (typically <10 mm/ka) are measured in  
713 Palaeozoic crustal provinces, such as the Southeastern part of Australia (Webb *et al.*, 1992) or  
714 on the Appalachian plateau (Granger *et al.*, 2001).

715

716 Most of the time, higher incision rates are related to periods of stronger uplift, such as in the  
717 Styrian Alps or the Western American Sierra Nevada, where Miocene uplift rates reached 140  
718 mm/ka (Stock *et al.*, 2005; Wagner *et al.*, 2010). Where karstification and fluvial dynamics  
719 have been studied in particular detail, it is possible to identify multiple uplift phases during the  
720 Cenozoic era. This is the case in the Languedocian plateaus where karstic and valley evolution  
721 corresponded to several uplift pulses since the Cretaceous period (Séranne *et al.*, 2002); the last  
722 pulse occurring during the Middle to Late Miocene. The onset of accelerated incision is related  
723 to Pliocene and Pleistocene tectonic uplift and climate change, in the Sierra Nevada (from 3  
724 and 1.5 Ma; Stock *et al.*, 2005), in the middle Ardèche valley (since 2 Ma; Audra *et al.*, 2001)  
725 or in the Eastern Pyrenees (since the beginning of the Pleistocene; Calvet *et al.*, 2015).  
726 Variations in tectonically- and climatically-driven incision rates are conditioned locally by  
727 geomorphology and fluvial behavior, such as river capture. In the Styrian Alps, strong incision  
728 of the Mur River, from 4 to 2.5 Ma was connected with an extension of the Mur catchment  
729 following river drainage change (Wagner *et al.*, 2010). Decreased incision during the  
730 Quaternary corresponded to fluvial aggradation during Pleistocene cold periods and reduced  
731 potential for bedrock entrenchment. Short-term increase in incision rate in the Siebenhengste at  
732 800 ka has been related to a change in flow direction from the Eriz valley to the south, to the  
733 Aare valley in the north (Häuselmann & Granger, 2005). Similar short-term changes in incision  
734 rate are evident in the Mammoth Cave record, where an incision event at c. 1.4 Ma has been  
735 correlated with headward erosion in the Green River valley, after the formation of the Ohio  
736 River, at the end of an ice-sheet advance (Granger *et al.*, 2001).

737

738 Delayed response between tectonic uplift and resulting fluvial incision can also be discerned  
739 from the karst-fluvial archive. This is the case in the Ardenne massif where <sup>10</sup>Be dating  
740 highlighted diachronous river incision from the lower Meuse valley at the northern rim of the  
741 Ardenne to its intra-massif (sub-) tributaries, i.e. Belle-Roche in the Amblève valley (Rixhon  
742 *et al.*, 2011, 2014). However, rates of knickpoint retreat are variable, and depend on many  
743 factors, including climate, discharge, lithology, tectonics and time (Whittaker & Boulton,  
744 2012). These controls are translated into the morphosedimentary record as spatial variations in  
745 the timing of uplift, valley incision, aggradation, and karstification. In the Upper Yangzi

746 catchment, cosmogenic nuclide ages suggest a considerably delayed response (c. 20 Ma)  
747 between Late Eocene uplift (Hoke *et al.*, 2014) and Miocene incision (from 18 to 9 Ma), such  
748 that valley incision is not a useful proxy for surface uplift (McPhillips *et al.*, 2016).

749

## 750 **5.2. Models of valley evolution and karstification**

751

752 At the regional scale (e.g. across the Mediterranean basin), eustatic, isostatic, tectonic and  
753 climatic factors, largely explain the rise or fall of base and cave levels. These drivers do not  
754 influence hypogenic caves and ghost rocks (isovolumetric weathering with very low flow)  
755 because these types of speleogenesis are not connected to a fluvial base level. However, uplifted  
756 hypogenic and ghost rock karsts can be reactivated, as cryptokarsts (when karstification occurs  
757 under an impervious sedimentary cover) or palaeokarsts, when they can be influenced by base  
758 and cave level change (e.g. Wealdian: continental Infra-Cretaceous (Vergari & Quinif, 1997;  
759 Jaillet *et al.*, 2004). In most karst regions, geomorphological evolution consists of valley  
760 incision and *per descensum* speleogenesis. Over Quaternary timescales, this model is  
761 underpinned by climate change, since tectonic uplift and subsidence change over much longer  
762 geological time spans. Thus, Quaternary glacial and interglacial cycles are recorded in terraces  
763 and caves by aggradation, incision, or concretion phases (Antoine, 1994; Quinif, 2006;  
764 Columbu *et al.*, 2015).

765

766 At the catchment scale, Pleistocene climatic cycles and geomorphological factors influenced  
767 fluvial and karstic environments. In many catchments, river incision chiefly occurs during cold-  
768 to-warm or warm-to-cold climatic transitions, in accordance with regional climate change  
769 (Antoine, 1994; Bridgland *et al.*, 2009). Underground streams adjust to falling base level by  
770 incising new passages. However, there is evidence that *per descensum* speleogenesis also  
771 depends on the timing of valley incision, as well as geological factors such as (i) the degree of  
772 bedrock karstification (Abel *et al.*, 2002), (ii) alternating pervious and impervious strata causing  
773 perched karsts (Devos *et al.*, 2015, Figure 4A level a) and iii) underground karstic flows towards  
774 a lower elevation river in a neighbouring hydrographic basin or in the downstream position of  
775 the same river (Losson, 2003). As a consequence, numerous interactions between fluvial  
776 evolution and karstification can exist. We therefore propose four local to regional models of  
777 Quaternary geomorphological evolution from different settings: 1) Eastern Pyrenees, in  
778 limestone rocks, 2 and 3) low limestone plateaus of the Eastern Paris Basin and 4) a rapidly-



779 uplifted gypsum area in the Northern Apennines, Italy (Losson, 2003; Antoine *et al.*, 2006; Hez  
780 *et al.*, 2015; Colombu *et al.*, 2015).

781

### 782 **5.2.1 A conceptual model of valley scale karstic and fluvial development: river terrace** 783 **records in the Têt basin (Eastern French Pyrenees)**

784

785 On the basis of river terrace records from the Eastern French Pyrenees (Calvet *et al.*, 2015; Hez  
786 *et al.*, 2015), a valley-scale conceptual model of karst drainage evolution is presented in Figure  
787 7. This reflects changes in karst genesis, evolution, and abandonment as well as fluvial incision  
788 into bedrock, sediment aggradation, and terrace incision/abandonment. This model is based on  
789 cavities in the Têt basin, especially in the Devonian limestones syncline of Villefranche, where  
790 nine horizontal conduits exist up to 1,000 m above the present valley floor (Hez *et al.*, 2015;  
791 Calvet *et al.*, 2015). The two lowest karstic tubes contain rich morphologies of sediment fill  
792 and corrosion forms, which can be explained by the succession of three genetic karstic phases  
793 (Figure 7A, C). In phase 1, the presence of phreatic caves indicates syngenetic karstification  
794 below base level during or after valley incision. In phase 2, bench walls and the corroded ceiling  
795 of the horizontal conduit indicate aggradation at the valley bottom leading to progressive and  
796 synchronous base-level rise during a paragenetic phase. During phase 3, funnel shaped conduits  
797 cutting down into the horizontal tubes highlight a period of renewed incision (“trepanning”,  
798 Jaillet *et al.*, 2004). This suggests a diachronic evolution of the caves with: a) lowering of the  
799 base-level inducing downstream incision of the paragenetic stage sediments. Thus, ancient  
800 horizontal conduits shaped in the flooded zone evolve downstream in the vadose zone where  
801 the cave deposits are partially reworked (see phase 1); b) formation of bench walls in the middle  
802 part of the galleries; and c) deposition of a cave fan delta upstream. Indeed, a strong hydraulic  
803 gradient (1/1000) and flooding on the perched valley floor causes upstream transport and  
804 deposition of coarse alluvium in karstic caves. In a last stage d), headward erosion along the  
805 valley axis induces fluvial incision of the alluvial plain and underlying bedrock, and  
806 entrenchment of the cave fill. Beneath the valley floor, a karstic drain is initiated in the flooded  
807 zone (Figure 7B).

808

809 One must note that this model of karstic drain evolution and the relationships between valley  
810 and karstic development during a Pleistocene climatic cycle is not valid when underground flow  
811 is diverted to stream capture or piracy (see below, Figure 8B). Thus, in the capture area of the

812 Moselle river by the Meurthe (Losson, 2003), the caves of Pierre-la-Treiche show that the  
813 endokarstic networks are not correlated in elevation with the Moselle terraces.

814

### 815 **5.2.2. Two conceptual models of regional karstic and fluvial development in low limestone** 816 **plateaus: cave records**

817

818 In limestone plateaus, alluvial stepped terraces and tiered cave infills record successive  
819 Milankovitch cycles of palaeoenvironmental change (Figure 8). In both models (Figure 8A and  
820 8B), two positions are distinguished based to the type of speleogenesis. Figure 8A shows the  
821 evolution of a plateau karst where the caves are in connection with the valley bottom. Figure  
822 8B presents a valley karst. The lower caves, situated below the water table, are in connection  
823 with the base level of another valley which is located below the water table, as in Pierre-la-  
824 Treiche (Losson *et al.*, 2006). Figure 8B3 presents a valley karst where underground flows  
825 occur between zones of karstic losses and resurgences along the same valley, such as the upper  
826 Meuse upstream of Neufchâteau, Eastern Paris basin (Losson, 2003).

827

828 In both models, stage 1 corresponds to an interglacial period with pedogenesis and silt  
829 deposition in river systems and caves. Biological CO<sub>2</sub> allows speleothem, travertine and tufa  
830 growth, especially in warm environments or in chalk Cretaceous catchments where thick tufa  
831 deposits occur (Antoine *et al.*, 2006, Figure 8A). During stage 2, at the onset of climate cooling,  
832 the progressive disappearance of forests leads to soil erosion on the slopes, lateral erosion in  
833 the meandering valleys, and headward erosion of the steep slopes of the karstic massif (Antoine,  
834 1994). As a consequence, cave entrances become disconnected from the valley bottom in a  
835 plateau karst (Figure 8A). There is little or no speleothem growth in vadose caves and fine  
836 clastic deposits (from soil erosion) are deposited in flooded cavities. Lower flooded caves are  
837 situated below the water table in relation to neighbouring valley (such as the Palaeo-Meurthe  
838 valley, Figure 8B). In the cold period (stage 3), for example in the Moselle valley (Figure 8B),  
839 the river entrenches into the bedrock, above the former flooded caves connected with the  
840 Palaeo-Meurthe river. In stage 4, during full glacial conditions (such as the Last Glacial  
841 Maximum, MIS 2), coarse alluvium, originating from the glaciated Vosges massif, was  
842 deposited by a braided river in the valley bottom. This material was also deposited in the lower  
843 elevation flooded or vadose caves (Losson *et al.*, 2006). In fact, glaciated karst regions where  
844 a major glacial advance occurs generates large volumes of sediment that are deposited in karst  
845 cavities at the surface and subsurface, leading to major phases of aggradation

846 (e.g. Lewin & Woodward, 2009; Adamson *et al.*, 2014, 2016a and b). No speleothem formation  
847 occurs during full glacial conditions (Fairchild and Baker, 2012).

848

849 When large volumes of alluvium are deposited on the valley floor, they can fill caves that are  
850 situated (almost) at the same altitude as the river (Figure 8A), such as the Middle Pleistocene  
851 filling of the Belle-Roche cave in the Ardenne massif (Rixhon *et al.*, 2014). Some authors have  
852 highlighted the difference between wet glacial periods characterized by sediment-laden rivers,  
853 and dry cold periods with reworked loess, for example in Belgian caves, close to the former  
854 margins of the Fennoscandian ice sheet (Quinif, 2006). Where caves have become filled, they  
855 display evidence of a complex geomorphological evolution, with successive phases of  
856 aggradation and incision (Quinif & Maire, 1998).

857

858 The wide caves of Pierre-la-Treiche, filled with coarse grained alluvium (Figure 8B) indicate a  
859 speleogenetic phase during an interglacial period, before the deposition of alluvium in the  
860 subsequent glaciation. However, the horizontal cave levels of the (epi)phreatic zone, which  
861 correspond to stable base levels without tectonic uplift, require a minimum formation time by  
862 solutional processes of 10-40 ka (Ford & Williams, 1989). The time period between two  
863 Quaternary glaciations (MIS 5e, c, a) is thus long enough for dissolution processes to excavate  
864 the horizontal tubes. During the subsequent interglacial, new flooded caves were formed at the  
865 bottom of the valley where tufa deposits can develop (Antoine *et al.*, 2006; Dabkowski *et al.*,  
866 2011; Figure 8A). Today, at Pierre-la-Treiche, the entrenched valley of the Moselle is situated  
867 below the vadose caves (Losson, 2003; Cordier *et al.*, 2006) where speleothems have grown  
868 since 300 ka, spanning several interglacial and interstadial periods (Losson, 2003, Losson *et*  
869 *al.*, 2006; Pons-Branchu *et al.*, 2010).

870

### 871 **5.2.3. Model of climate-driven speleogenesis of gypsum caves**

872

873 Figure 9 presents a model of climate-driven river incision and karstification based on the multi-  
874 level gypsum cave systems of the Re Tiberio (Fig. 1) situated in the moderately-rapidly uplifted  
875 Northern Apennines, Italy (Columbu *et al.*, 2015). This Italian karstified area presents a more  
876 relevant model than the Spanish karsts, where the subsidence is irregular in time and space  
877 (Gállego valley) or where the geomorphological evolution is accelerated by a river capture  
878 event (Rio Aguas, Sorbas basin, see 4.4). Mostly, in the Re Tiberio valley, dating speleothems  
879 provide a more precise chronological framework (Columbu *et al.*, 2015). U-series ages of

880 calcite speleothems from the three cave levels, situated at 340, 215, and 190 m a.s.l., revealed  
881 growth phases during the MIS 5e, MIS 5d-c (Dansgaard-Oeschger cycle 24) and MIS 5b-a (D-  
882 O cycles 22 to 20), respectively. The ages suggest rapid entrenchment during cold periods,  
883 because uplift rates had reached c. 1 mm/yr since the end of the Middle Pleistocene (Columbu  
884 *et al.*, 2015).

885

886 This model presents significant differences with previous conceptual models (see Figs 7 and 8),  
887 because horizontal cave levels formed during cold periods. Karst evolution was rapid,  
888 especially during wetter phases, due to increased bedload (Figure 9B2, 9B3, 9B4). Valley  
889 aggradation led to the infilling of cave passages and a paragenetic karstification due to slowly  
890 rising base level. During the subsequent warm period, decreased bedload initiated incision into  
891 the cave sediments, but karstification was slow (Figure 9A, 9B5). The key similarities with the  
892 models presented in Figures 7 and 8, are that carbonate speleothems grew during wet and warm  
893 interglacials or interstadials (MIS 5e, 5d-a, 5b-a, figure 9A, 9B1) and valley incision occurred  
894 at cooling transitions due to high stream discharge and low bedload concentrations (figure 9B2).

895

#### 896 **5.2.4. Diverse models of karstic and valley evolution**

897

898 The four models outlined above present idealised scenarios, based on existing evidence, but  
899 more complex models of fluvial and karstic evolution can occur in response to local to regional  
900 conditions. Thus, successive aggradation or erosion phases can occur over multiple cold  
901 periods. These can be recorded in the same cave level, as in the Pierre-Saint-Martin caves in  
902 the French Pyrenees (Quinif & Maire, 1998). On the other hand, tiered caves can be filled with  
903 deposits of the same age, as in the Mammoth cave, USA (Granger *et al.*, 2001). Establishing  
904 the model of karst and valley evolution in different settings relies on the number of cave levels  
905 and river terrace surfaces in a connected valley. However, the number of cave passage levels  
906 present in karst landscapes is commonly lower than the number of 100 ka cycles that have  
907 occurred over the last 1 Ma of the Quaternary. This suggests that karst-fluvial systems might  
908 record only the major climate changes ('supercycles' of Kukla, 2005; Bridgland *et al.*, 2009)  
909 or/and variations in uplift rate.

910

## 911 **6. Conclusion**

912

913 For two decades, analysis of river systems in karstic areas, including the wider application of  
914 dating methods, such as cosmogenic nuclide dating of cave infills, have provided a better  
915 understanding of geomorphological evolution over the Cenozoic era, especially during the  
916 Quaternary. Alluvial records in karst terrain, especially in European karst catchments, where  
917 the sedimentary records are particularly well preserved compared to their sub-aerial  
918 counterparts, now provide a reliable record of landscape evolution that can be effectively tied  
919 to wider, regional morphosedimentary archives.

920

921 Evidence indicates that many factors, including uplift, eustatic fluctuations, climatic conditions  
922 and fluvial dynamics (e.g. knickpoint retreat, increased channel flow and/or sediment load, and  
923 stream piracy), can play a major role in speleogenesis and geomorphological evolution. Data  
924 reviewed here have allowed us to propose a four-fold typology of the relationship between  
925 fluvial evolution and karstification: 1) karstification in association with base and cave level  
926 lowering, i) in low elevation and tectonically-stable cratonic area, ii) on low altitude plateaus  
927 (<500 m a.s.l.), iii) on high altitude plateaus and low mountain ranges (500 – 2,000 a.s.l.), where  
928 long-term records of fluvial incision and karstification are present; iv) in high mountain regions  
929 (>2,000 m a.s.l.), 2) karstification in association with rising base and cave level, 3) Pleistocene  
930 incision and karstification in association with glaciation, and 4) the particular case of karstified  
931 evaporites. In, gypsum and salt speleogenesis is characterized by rapid dissolution and  
932 subsidence. In European catchments, gypsum cave enlargement has occurred during cold  
933 climate periods, while limestone caves formed during warm interglacial or interstadial phases.  
934 However, in limestone rocks, the bulk of karstic cave fills correspond to cold periods, with  
935 thick, clastic sediments deposited under glacial conditions. Speleothems and tufa deposits are  
936 formed chiefly during interglacial periods. This demonstrates that, over Quaternary timescales,  
937 climate plays an important role in karst processes. The regional and local setting determines the  
938 modes of valley evolution and karstification, and the geomorphological framework plays a  
939 triggering factor to initiate speleogenesis.

940

941 In addition, our synthesis is used to propose four models of fluvial and karst evolution, from  
942 different settings: 1) in the Eastern Pyrenees, in limestone rocks, 2 and 3) in low elevation  
943 limestone plateaus of the Eastern Paris Basin, and 4) a rapidly-uplifted gypsum area in the  
944 Northern Apennines, Italy.

945

946 Future research should focus on improved reliability and application of dating methods,  
947 because in many cases, numerical dating is not possible, due to a lack of alluvial sequences  
948 such as fluvial terraces or sedimentary fills within karstic caves and surface depressions (such  
949 as poljes and dolines). Even if alluvium is preserved in karstic terrain, it may not contain  
950 sufficient siliceous content for OSL dating, or secondary carbonate concretions, such as  
951 travertine or calcrete, for U-series dating. Moreover, U-series dating is further complicated by  
952 the ingrowth of younger calcite into pre-existing sediments. Alluvial sequences might also bear  
953 the imprint of sediment reworking, meaning that the sedimentary sequence is not indicative of  
954 primary formation mechanisms. Further research should also include other karstic regions,  
955 especially low latitude regions, as well as arid regions, around the Mediterranean Sea, to  
956 enhance our understanding of karstic processes in other global regions.

957

958

## 959 **References**

960

961 Abel, T., Hinderer, M., Sauter, M., 2002. Karst genesis of the Swabian Alb, south  
962 Germany, since the Pliocene. *Acta Geologica Polonica*, 52, 1, 43–54.

963 Adamson, K.R., Woodward, J.C., Hughes, P.D., 2014. Glaciers and rivers: Pleistocene  
964 uncoupling in a Mediterranean mountain karst. *Quaternary Science Reviews* 94, 28–43.

965 Adamson, K., Candy, I., Whitfield, L., 2015. Coupled micromorphological and stable isotope  
966 analysis of Quaternary calcrete development. *Quaternary Research*, 84 (2), 272–286.

967 Adamson, K. R., Woodward, J. C., Hughes, P. D. 2016a. Middle Pleistocene glacial outwash  
968 in poljes of the Dinaric karst. *In: Gao, Y. and Alexander Jr, E.C (Eds) Caves and Karst Across*  
969 *Time. Geological Society of America, Vol. 516, 247–263.*

970 Adamson, K.R., Woodward, J.C., Hughes, P.D., Giglio, F., Del Bianco, F., 2016b. Middle  
971 Pleistocene glaciation, alluvial fan development and sea-level changes in the Bay of Kotor,  
972 Montenegro. *In: Hughes, P. D. and Woodward, J. C. (Eds) Quaternary Glaciation in the*  
973 *Mediterranean Mountains Geological Society, London, Special Publications, 433, SP433-13.*

974 Ambert, M. and Ambert P., 1995. Karstification des plateaux et encaissement des vallées au  
975 cours du Néogène et du Quaternaire dans les Grands Causses méridionaux (Larzac, Blandas).  
976 *Géologie de la France*, 4, 37–50.

977 Anthony, D.M., and Granger, D.E., 2007. A new chronology for the age of Appalachian  
978 erosional surfaces determined by cosmogenic nuclides in cave sediments. *Earth Surface*  
979 *Processes and Landforms. Volume 32, Issue 6, 874–887.*

980 Antoine, P., 1994. The Somme Valley terrace system (northern France): a model of river  
981 response to Quaternary climatic variations since 800,000 BP. *Terra Nova* 6, 453–464.

982 Antoine, P., Lautridou, J.P, Laurent, M., 2000. Long-term fluvial archives in NW France:  
983 response of the Seine and Somme rivers to tectonic movements, climatic variations and sea-  
984 level changes. *Geomorphology* 33, 3-4,183–207.

985 Antoine, P., Limondin-Lozouet, N., Auguste, P., Lochet, J.L., Galheb, B., Reyss, J.L., Escude,  
986 E., Carbonel, P., Mercier, N., Bahain, J.J., Falguères, C., Voinchet, P., 2006. Le tuf de Caours  
987 (Somme, France): mise en évidence d'une séquence éémienne et d'un site paléolithique associé.  
988 *Quaternaire* 17,4, 281-320.

989 Audra, P., Ed., 2010, Grottes et karsts de France. *Karstologia Mémoires*, n° 19, 44–45.

990 Audra, P., 2010, La spéléogénèse épigène. *In: Audra, P., Ed, 2010. Grottes et karsts de France.*  
991 *Karstologia Mémoires*, 19, 44–45.

992 Audra, P., Camus, H., Rochette, P., 2001. Le karst des plateaux jurassiques de la moyenne  
993 vallée de l'Ardèche : datations par paléomagnétisme des phases d'évolution plio-quaternaire  
994 (aven de la Combe Rajeau). *Bull. Soc. Géol. France*, 172, 1, 121–129.

995 Audra, P., Mocochain, L., Camus, H., Gilli, É., Clauzon, G., Bigot, J.-Y., 2004. The effect of  
996 the Messinian Deep Stage on karst development around the Mediterranean Sea. Examples from  
997 Southern France. *Geodinamica Acta*, 17, 6, 27–38.

998 Audra P., Bini A., Gabrovsek F., Häuselmann P., Hobléa F., Jeannin P.Y., Kunaver J.,  
999 Monbaron M., Sustersic F., Tognini P., Trimmel H., Wilberger A., 2007. Cave and karst  
1000 evolution in the Alps and their relation to paleoclimate and paleotopography. *Acta Carsologica*  
1001 36-1, 53–67.

1002 Audra, P., Mocochain, L., Bigot, J.-Y., Nobécourt, J.-C., 2009. The association between bubble  
1003 trails and folia: a morphological and sedimentary indicator of hypogenic speleogenesis by  
1004 degassing, example from Adaouste Cave (Provence, France). *International Journal of*  
1005 *Speleology*, Bologna, 38, 2: 93-102.

1006 Audra, P. and Palmer, A.N., 2011. The pattern of caves: controls of epigenic speleogenesis.  
1007 *Géomorphologie*, 4, 359–378.

1008 Audra, P. and Palmer, A.N., 2013. The vertical dimension of karst: controls of vertical cave  
1009 pattern. *In: Shroder, J. (Editor in chief), Frumkin, A. (Ed.), Treatise on Geomorphology.*  
1010 *Academic Press, San Diego, CA*, 6, *Karst Geomorphology*, 186–206.

1011 Bastin, B. and Gewalt, M., 1986. Analyse pollinique et datation <sup>14</sup>C de concrétions  
1012 stalagmitiques holocènes : apports complémentaires des deux méthodes. *Géographie physique*  
1013 *et Quaternaire*, 40, 2, 185-196.

1014 Bazalgette, L. and Petit, J.P., 2005. Fold amplification and style transition involving fractured  
1015 dip-domain boundaries; buckling experiments in brittle paraffin wax multilayers and  
1016 comparison with natural examples. *Geological Society Special Publications (2007) 270*: 157-  
1017 169.

1018 Benito, G., Pérez-González, A., Gutiérrez, F., Machado, M.J., 1998. River response to  
1019 Quaternary subsidence due to evaporite solution (Gállego River, Ebro Basin, Spain).  
1020 *Geomorphology 22*, 243–263.

1021 Benito, G., Sancho, C., Peña, J.L., Machado, M.J., Rhodes, E.J., 2010. Large-scale karst  
1022 subsidence and accelerated fluvial aggradation during MIS6 in NE Spain: climatic and  
1023 paleohydrological implications. *Quaternary Science Reviews 29*, 2694–2704.

1024 Bigot, J.-Y. and Audra, P., 2010. Les cavités parakarstiques des grès et des conglomérats. *In*:  
1025 Audra, Ph., ed, 2010. *Grottes et karsts de France. Karstologia Mémoires*, 19, 84–85.

1026 Bridgland, D. and Westaway, R., 2007. Climatically controlled river terrace staircases: A  
1027 worldwide Quaternary phenomenon. *Geomorphology*, 98, 285-315.

1028 Bridgland, D., Westaway, R., Cordier, S., 2009. Les causes de l'étagement des terrasses  
1029 alluviales à travers le monde. *Quaternaire*, 20, 4, 5–23.

1030 Bruthans J. and Zeman O., 2003. Factors controlling exokarst morphology and sediment  
1031 transport through caves: comparison of carbonate and salt karst. *Acta Carsologica 32-1*, 83-99.

1032 Bruxelles, L., Astruc, J.-L., Simon-Coinçon, R., Ciszak, R., 2013. Histoire des paysages et  
1033 Préhistoire : l'apport de la connaissance géomorphologique du Quercy pour la compréhension  
1034 de l'environnement paléolithique. Actes de la session C67, XVème Congrès mondial de  
1035 l'UISPP, Lisbonne, sept. 2006, PALEO, supplément 4, 21–36.

1036 Buffard, R. and Fischer, H., 1993. Les gisements de fer de la région de Kisanga (Shaba  
1037 méridional, Zaïre), colmatages d'un paléokarst du Protérozoïque supérieur, *Karstologia*, 21, 51-  
1038 55.

1039 Calaforra, J.M. and Pulido-Bosch, A., 2003. Evolution of the gypsum karst of Sorbas (SE  
1040 Spain). *Geomorphology*, 50, 1, 173-180.

1041 Calvet, M., Gunnell, Y., Braucher, R., Hez, G., Bourlès, D., Guillouc, V., Delmas, M., ASTER  
1042 Team, 2015. Cave levels as proxies for measuring post-orogenic uplift: Evidence from  
1043 cosmogenic dating of alluvium-filled caves in the French Pyrenees, *Geomorphology*, 246, 617–  
1044 633.

1045 Campy, M., 1982. *Le Quaternaire franc-comtois. Essai chronologique et paléoclimatique.*  
1046 *Thèse d'État*, 575 p., Besançon.



1047 Camus, H., 1997. Formations des réseaux karstiques et creusement des vallées : l'exemple du  
1048 Larzac méridional, Hérault, France. *Karstologia*, 29, 1, 23–42.

1049 Camus, H., 2010. L'aven de la Leïcasse, un modèle de spéléogénèse des Causses méridionaux.  
1050 In: Audra, P., Ed, 2010. Grottes et karsts de France. *Karstologia Mémoires*, 19, 310–311.

1051 Candy, I., Black, S., Sellwood, B.W., 2005. U-series isochron dating of immature and mature  
1052 calcretes as a basis for constructing Quaternary landform chronologies for the Sorbas basin,  
1053 southeast Spain. *Quaternary Research*, 64 (1), 100-111.

1054 Clauzon, G., 1978. The Messinian Var canyon (Provence, Southern France). Paleogeographic  
1055 implications. *Marine Geology* 27, 3-4, 231–246.

1056 Columbu, A., De Waele, J., Forti, P., Montagna, P., Picotti, V., Pons-Branchu, E., Hellstrom,  
1057 J., Bajo, P., Drysdale, R., 2015. Gypsum caves as indicators of climate-driven river incision  
1058 and aggradation in a rapidly uplifting region. *Geology*, 43, 6, 539-542.

1059 Cordier, S., Harmand, D., Frechen, M., Beiner, M., 2006: Fluvial system response to Middle  
1060 and Upper Pleistocene climate change in the Meurthe and Moselle valleys (Eastern Paris Basin  
1061 and Rhenish Massif). *Quaternary Science Reviews*, 25, 1460–1474.

1062 Cordy, J.-M., Bastin, B., Demaret-Fairon, M., Ek, C., Geeraerts, R., Groessens-Van Dyck,  
1063 M.C., Oze, A., Peuchot, R., Quinif, Y., Thorez, J., Ulrix-Closset, M., 1993. La grotte de la  
1064 Belle-Roche (Sprimont, Province de Liège) : un gisement paléontologique et archéologique  
1065 d'exception au Bénélux. *Bull. de la Classe des sciences, Académie royale de Belgique*, 1-6,  
1066 165–186.

1067 Couchoud, I., 2008. Les spéléothèmes, archives des variations paléoenvironnementales.  
1068 *Quaternaire*, 19, 4, 255–274.

1069 Dabkowski, J., Limondin-Lozouet, N., Antoine, P., Marca-Bell, A., Andrews, J., 2011.  
1070 Enregistrement des variations climatiques au cours des interglaciaires d'après l'étude des  
1071 isotopes stables de la calcite de tufs calcaires pléistocènes du nord de la France : exemple des  
1072 séquences de Caours (SIM 5e ; Somme) et de La Celle-Sur-Seine (SIM 11 ; Seine-et- Marne).  
1073 *Quaternaire*, 22, (4), 275-283.

1074 Dabkowski, J., Limondin-Lozouet, N., Anders, J., Marca-Bell, A., Antoine, P., 2016. Climatic  
1075 and environmental variations during the Last Interglacial recorded in a Northern France Tufa  
1076 (Caours, Somme Basin). Comparisons with regional to global records. *Quaternaire*, 27, (3),  
1077 249-261.

1078 Delannoy, J.-J., 1982. Les variations spatio-temporelles de la corrosion karstique dans un  
1079 massif de moyenne montagne : le Vercors. *Revue de géographie alpine*, 70, 3, 241-255.

1080 Delannoy, J.-J., 1997, Recherches géomorphologiques sur les massifs karstiques du Vercors et  
1081 de la transversale de Ronda (Andalousie). Les apports morphogéniques du karst. Thèse de  
1082 doctorat d'état en géographie / Université Joseph Fourier / Grenoble 1, 706 p.

1083 Delannoy, J.-J., Perrette, Y., Destombes, J.-L., Peiry, J.-L., 1999. Excursion 4 : le Vercors.  
1084 Itinéraire : Ste Eulalie-en-Royans - Grands Goulets - Val médian - Gorges de la Bourne -  
1085 Grottes de Choranche. Cahiers savoisiens de Géographie, [field excursions guide of the  
1086 European Conference "Karst 99", Grands Causses - Vercors, 10-15 September 1999],  
1087 Université de Savoie: 75-108.

1088 Devos, A., Lejeune, O., Chopin, E., 2007. Structural control on surface flow in karstic  
1089 environnement, *Geodinamica Acta*, 20/6, 393–402.

1090 Devos, A., Sosson, C., Fronteau, G., Lejeune, O., 2009. Les tuffières de Vormy et des  
1091 Fontinettes (Aisne, Marne, France): marqueurs de la faible karstification des calcaires lutétiens  
1092 de l'Est du Bassin parisien? *Karstologia* 54, 37–48.

1093 Devos, A., Chalumeau, Sosson, C., Fronteau, G., Turmel, A., Lejeune, O., 2011: La  
1094 fantômisiation des calcaires lutétiens du bassin de Paris – Apport des carrières souterraines,  
1095 *Karstologia* 58, 15–28.

1096 Devos, A., Bollot, N., Chalumeau, L., Fronteau, G., Lejeune, O., 2015. Impact of lateral  
1097 variations of geologic facies on water resources in homogeneous basins - Example of tertiary  
1098 plateaus in the Paris Basin. *Geodinamica acta*, 27, 1, 15–24.

1099 Dunai, T., 2010. *Cosmogenic nuclides - Principles, Concepts and Applications in the Earth*  
1100 *Surface Sciences*, Cambridge University Press, 187 p.

1101 Ek, C., 1961. Conduits souterrains en relation avec les terrasses fluviales. *Annales de la Société*  
1102 *géologique de Belgique*, Liège, t. LXXXIV, 313–340.

1103 Fairchild, I. J. and Baker, A., 2012. *Speleothem Science: From Process to Past Environments*,  
1104 Wiley-Blackwell, 450 p.

1105 Ford, D.C. and Ewers, R.O., 1978. The development of limestone cave systems in the  
1106 dimensions of length and depth. *International Journal of Speleology*, 10, 213–244.

1107 Ford, D. and Williams, P., 1989. *Karst geomorphology and hydrology*, Unwin Hyman, 601 p.

1108 Frank, N., Kober, B., Mangini, A., 2006. Carbonate precipitation, U-series dating and U-  
1109 isotopic variations in a Holocene travertine platform at Bad Langensalza - Thuringia Basin,  
1110 Germany. *In: Tufs calcaires et travertins quaternaires: morphogénèse, biocénoses, paléoclimats*  
1111 *et implantations paléolithiques. 2ème partie. Quaternaire*, 17, 4, 333–342.

1112 Gabrovšek, F., Häuselmann, P., Audra, P., 2014. 'Looping caves' versus 'water table caves':  
1113 the role of base-level changes and recharge variations in cave development. *Geomorphology*

1114 204, 683–691.

1115 Gázquez, F., Calaforra, J.M., Evans, N.P., Hodell, D.A., 2016. Using stable isotopes ( $\delta^{18}\text{O}$  and  
1116  $\delta\text{D}$ ) of gypsum hydration water to unravel the mode of gypsum speleothem formation in semi-  
1117 arid caves. EGU General Assembly 2016, held 17-22 April, 2016 in Vienna Austria, p.8911.

1118 Gilli, E., 2010. Les grands volumes karstiques souterrains. *In*: Audra, P., Ed, Grottes et karsts  
1119 de France. Karstologia Mémoires, 19, 54-55.

1120 Granger, D.E., 2014. Cosmogenic Nuclide Burial Dating in Archaeology and  
1121 Paleoanthropology. *In*: Treatise on Geochemistry: Second Edition. Elsevier Ltd, 81–97.

1122 Granger, D.E., Kirchner, J.W., Finkel, R.C., 1997. Quaternary downcutting rate of the New  
1123 River, Virginia, measured from differential decay of cosmogenic  $^{26}\text{Al}$  and  $^{10}\text{Be}$  in cave-  
1124 deposited alluvium. *Geology*, 25, 2, 107–110.

1125 Granger, D.E., Fabel, D., Palmer, A.N., 2001. Pliocene–Pleistocene incision of the Green River,  
1126 Kentucky, determined from radioactive decay of cosmogenic  $^{26}\text{Al}$  and  $^{10}\text{Be}$  in Mammoth Cave  
1127 sediments: *Geological Society of America Bulletin*, 113, 825–836.

1128 Granger, D.E. and Muzikar, P.F., 2001. Dating sediment burial with in situ-produced  
1129 cosmogenic nuclides: theory, techniques, and limitations. *Earth Planet. Sci. Lett.* 188, 269–281.

1130 Guifang, Y., Xujiao Zh., Mingzhong T., Yamin P., Anze C., Zhiliang G., Zhiyun N., Zhen Y.,  
1131 2011. Geomorphological and sedimentological comparison of fluvial terraces and karst caves  
1132 in Zhangjiajie, northwest Hunan, China: an archive of sandstone landform development.  
1133 *Environ Earth Sci*, 64, 671–683.

1134 Habib, B., 2015. Relations entre karstification, cadre morphostructural et incisions des vallées  
1135 dans les calcaires du Dogger en Haute-Saône (plateaux de Vesoul et de Combeaufontaine).  
1136 Thèse de doctorat, Université de Lorraine, 460 p.

1137 Harmand, D., Lejeune, O., Jaillet, S., Allouc, J., Occhietti, S., Brulhet, J., Devos, A., Fauvel,  
1138 P.-J., Hamelin, B., Laurain, M., Le Roux, J., Marre, A., Pons-Branchu, E., Quinif, Y., 2004.  
1139 Dynamique de l'érosion dans le Barrois et le Perthois: incision et karstification dans les bassins-  
1140 versants de la Marne, la Saulx et l'Ornain. *Quaternaire*, 15, 4, 305–318.

1141 Harmand, D. and Cordier, S., 2012. The Pleistocene terrace staircases of the present and past  
1142 rivers downstream from the Vosges Massif (Meuse and Moselle catchments). *Netherlands*  
1143 *Journal of geosciences-Geologie en Mijnbouw*, 91-1/2, 91–109.

1144 Harvey, A.M., Whitfield, E., Stokes, M. & Mather, A.E. 2014. The late Neogene to Quaternary  
1145 drainage evolution of the uplifted Neogene Sedimentary Basins of Almeria, Betic Chain.  
1146 *Landscapes and Landforms of Spain*, 37-61.

1147 Häuselmann, P., 2002. Cave genesis and its relationship to surface processes: Investigations in  
1148 the Siebenhengste region (BE, Switzerland). - PhD thesis, Université de Fribourg, 168 p.

1149 Häuselmann, P. and Granger, D.E., 2005. Dating of caves by cosmogenic nuclides: method,  
1150 possibilities, and the Siebenhengste example (Switzerland). *Acta Carsologica*, 34/1, 3, 43–50.

1151 Häuselmann, P., Granger, D.E., Jeannin P.Y., Lauritzen S.E., 2007. Abrupt glacial valley  
1152 incision at 0.8 Ma dated from caves deposits in Switzerland, *Geology*, 35, 2, 143-146.

1153 Häuselmann, P., Mihevc, A., Pruner, P., Horáček, I., Čermák, S., Hercman, H., Sahy, D., Fiebig,  
1154 M., Hajna, N.Z., Bosák, P., 2015. Snežna jama (Slovenia): Interdisciplinary dating of cave  
1155 sediments and implication for landscape evolution. *Geomorphology*, 247, 10–24.

1156 Hez, G., Jaillet, S., Calvet, M., Delannoy, J.-J., 2015. Un enregistreur exceptionnel de l'incision  
1157 de la vallée de la Têt : Le karst de Villefranche. Pyrénées-Orientales – France. *Kartologia* n°  
1158 65, *in press*.

1159 Hill, C.A., 1987. Geology of Carlsbad Cavern and other caves in the Guadalupe Mountains,  
1160 New Mexico and Texas. New Mexico Bureau of Mines and Mineral Resources. Bulletin 117,  
1161 150 p.

1162 Hobléa, F., Jaillet, S., Maire, R., 2001. Erosion et ruissellement sur karst nu en contexte  
1163 subpolaire océanique : les îles calcaires de Patagonie (Magallanes, Chili). *Karstologia*, 38, 2,  
1164 13-18.

1165 Hobléa, F., Häuselmann, P., Kubik, P., 2011. Cosmogenic nuclide dating of cave deposits of  
1166 Mount Granier (Hauts de Chartreuse Nature Reserve, France): morphogenic and  
1167 palaeogeographical implications. *Géomorphologie: relief, processus, environnement* 4, 395–  
1168 406.

1169 Hoke, G. D., Liu-Zeng, J., Hren, M. T., Wissink, G. K., and Garzione, C. N., 2014. Stable  
1170 isotopes reveal high southeast Tibetan Plateau margin since the Paleogene. *Earth and Planetary  
1171 Science Letters*, 394, 270-278.

1172 Hughes, P. D., Woodward, J. C. and Gibbard, P. L. (2006). Quaternary glacial history of the  
1173 Mediterranean mountains. *Progress in Physical Geography*, 30(3), 334-364.

1174 Hughes, P. D., Woodward, J. C., van Calsteren, P. C., Thomas, L. E., Adamson, K. R., 2010,  
1175 Pleistocene ice caps on the coastal mountains of the Adriatic Sea. *Quaternary Science Reviews*,  
1176 29 (27-28), 3690–3708.

1177 Hughes, P.D., Woodward, J.C., Van Calsteren, P.C. and Thomas, L.E., 2011. The glacial  
1178 history of the Dinaric Alps, Montenegro. *Quaternary Science Reviews*, 30(23), 3393-3412.

1179 Huxtable, J., Aitken, M. J., 1991. Thermoluminescence dating: results for the late Pleistocene.  
1180 In: Raynal, J.-P., Miallier, D. (éd.). *Datation et caractérisation des milieux pléistocènes*. Cah.

1181 Quat., CNRS, Paris (actes des symposiums 11 et 17 de la 11<sup>ème</sup> réunion des Sciences de la  
1182 Terre, Clermont-Ferrand, 25-27 mars 1986), 16, 19-24.

1183 Jaillet, S., 2000. Un karst couvert de bas-plateau : le Barrois (Lorraine / Champagne, France).  
1184 Structure - Fonctionnement - Evolution. Thèse de doctorat, Université de Bordeaux III, 2 vol.,  
1185 712 p.

1186 Jaillet, S., Pons-branchu, E., Brulhet, J., Hamelin, B., 2004. Karstification as a  
1187 geomorphological witness of river incision: example of the Marne Valley and Cousance karst  
1188 system (Eastern Paris Bassin). *Terra Nova*, 16, 4, 167–172.

1189 Kukla, G., 2005. Saalian supercycle, Mindel/Riss Interglacial and Milankovitch's dating.  
1190 *Quaternary Science Reviews*, 24, 14–15, 1573–1583.

1191 Le Roux, J. and Harmand, D., 1998. Contrôle morphostructural de l'histoire d'un réseau  
1192 hydrographique : le site de la capture de la Moselle. *Geodinamica acta*, 11, 4, 149-162.

1193 Le Roux, J. and Harmand, D., 2003. Origin of the hydrographic network in the Eastern Paris  
1194 Basin and its border massifs. Hypothesis, Structural, Morphologic and Hydrologic  
1195 consequences. Special conference on paleoweathering and paleosurfaces in the Ardenne-Eifel  
1196 region at Preizerdaul (Luxembourg) on 14 to 17 may 2003, Quesnel, coordinator, *Géologie de*  
1197 *la France*, 1, 4, 105-110.

1198 Lewin, J. and Gibbard, P.L., 2010. Quaternary river terraces in England: Forms, sediments and  
1199 processes. *Geomorphology* 120, 293-311.

1200 Lewin, J. and Woodward, J., 2009. Karst Geomorphology and Environmental Change  
1201 (chapter 10). *In: Woodward, J. Ed., 2009. The Physical Geography of the Mediterranean.*  
1202 *Oxford University Press*, 287-317.

1203 Limondin-Lozouet, N., Antoine, P., Auguste, P., Bahain, J.-J., Carbonel, P., Chaussé, Ch.,  
1204 Connet, N., Dupéron, J., Dupéron, M., Falguères, Ch., Freytet, P., Ghaleb, B., Jolly-Saad, M.-  
1205 C., Lhomme, V., Pierre Lozouet, P., Mercier, N., Pastre, J.-F., Voinchet, P., 2006. Le tuf  
1206 calcaire de La Celle-sur-Seine (Seine et Marne) : nouvelles données sur un site clé du stade 11  
1207 dans le Nord de la France. *Quaternaire*, 17, 2, 5–29.

1208 Liu, Y., Wang, S.J., Xu, S., Liu, X.M., Fabel, D., Zhang, X.B., Luo, W.J., Cheng, A.Y., 2013.  
1209 New evidence for the incision history of the Liuchong River, Southwest China, from  
1210 cosmogenic <sup>26</sup>Al/<sup>10</sup>Be burial ages in cave sediments. *J. Asian Earth Sci.*, 73, 274–283.

1211 Losson, B., 2003. Karstification et capture de la Moselle (Lorraine, France) : vers une  
1212 identification des interactions. Thèse de Géographie physique. Université de Metz. Vol. 1  
1213 (texte) : 510 p, Vol. des planches : 89 pl., Vol. des annexes, 227 p.

1214 Losson, B., Corbonnois, J., Argant, J., Brulhet, J., Pons-Branchu, E., Quinif, Y., 2006.  
1215 Interprétation paléoclimatique des remplissages endokarstiques de la vallée de la Moselle à  
1216 Pierre-la-Treiche (Lorraine, France). *Géomorphologie : relief, processus, environnement*, 1,  
1217 37–48.

1218 Lucha, P., Gutiérrez, F., Pedro Galve, J., Guerrero, J., 2012. Geomorphic and stratigraphic  
1219 evidence of incision-induced halokinetic uplift and dissolution subsidence in transverse  
1220 drainages crossing the evaporite-cored Barbastro–Balaguer Anticline (Ebro Basin, NE Spain).  
1221 *Geomorphology*, 171–172, 154–172.

1222 Mangin, A., 1975. Contribution à l'étude hydrodynamique des aquifères karstiques. *Annales de*  
1223 *spéléologie*, 29, n° 3, 283–332 ; 29, n° 4, 495–601 ; 30, n° 1, 21–124. Thèse d'état, Dijon.

1224 Mather, A.E., 2000. Adjustment of a drainage network to capture induced base-level change:  
1225 an example from the Sorbas Basin, SE Spain. *Geomorphology*, 34, 3-4, 271-289.

1226 McPhillips, D., Hoke, G. D., Liu-Zeng, J., Bierman, P. R., Rood, D. H., Niedermann, S., 2016.  
1227 Dating the incision of the Yangtze River gorge at the First Bend using three-nuclide burial ages,  
1228 *Geophys. Res. Lett.*, 43, 101–110.

1229 Mocochain, L., Clauzon, G., Bigot, J.-Y., 2006. Réponses de l'endokarst ardéchois aux  
1230 variations eustatiques générées par la crise de salinité messinienne. *Bulletin de la Société*  
1231 *géologique de France*, Paris, 177, 1, 27-36.

1232 Mocochain, L., Audra, P., Clauzon, G., Bellier, O., Bigot, J.-Y., Monteil, Ph., 2009. The effect  
1233 of river dynamics induced by the Messinian Salinity Crisis on karst landscape and caves:  
1234 example of the Lower Ardèche River (and Rhône valley). *Geomorphology*, 106, 46–61.

1235 Moreno, D., Falguères, Ch., Pérez-González, A., Duval, M., Voinchet, P., Benito-Calvo, A.,  
1236 Ortega, A. I., Bahain, J.-J., Sala, R., Carbonell, E., Bermúdez de Castro, J. M., Arsuaga, J.L.,  
1237 2012. ESR chronology of alluvial deposits in the Arlanzón valley (Atapuerca, Spain):  
1238 Contemporaneity with Atapuerca Gran Dolina site. *Quaternary Geochronology*, 10, 418–423.

1239 Nicod, J., 2010. Les étapes de la karstologie en France. *In*: Audra, P., Ed, 2010. *Grottes et karsts*  
1240 *de France*. *Karstologia Mémoires*, 19, 16–17.

1241 Ortega, A.I., Benito-Calvo, A., Pérez-González, A., Martín-Merino, M.A., Pérez-Martínez, R.,  
1242 Parés, J.M., Aramburu, A., Arsuaga, J.L., Bermúdez de Castro, J.M., Carbonell, E., 2013.  
1243 Evolution of multilevel caves in the Sierra de Atapuerca (Burgos, Spain) and its relations to  
1244 human occupation. *Geomorphology*, 196, 122–137.

1245 Osborne, R. A. L., 2007. The world's oldest caves: how did they survive and what can they tell  
1246 us? *Acta carsologica*, 36, 133–142.

1247 Palmer, A.N., 1991. Origin and morphology of limestone caves. Geological Society of America  
1248 Bulletin 103, 1-21.

1249 Palmer, A.N, 2007. Cave geology. Cave books, 454 p.

1250 Palmer, A.N. and Palmer, M.V., 1993, Geologic leveling survey in Logsdon River, Mammoth  
1251 Cave: Cave Research Foundation Annual Report 1992, 32–34.

1252 Piccini, L., 2011. Speleogenesis in highly geodynamic contexts: The quaternary evolution of  
1253 Monte Corchia multi-level karst system (Alpi Apuane, Italy). *Geomorphology*, 134, 49–61.

1254 Pons-Branchu E., Hamelin B., Losson B., Jaillet S., Brulhet J., 2010. Speleothem evidence of  
1255 warm episodes in northeast France during Marine Oxygen Isotope Stage 3 and implications for  
1256 permafrost distribution in northern Europe. *Quaternary Research*, 2010, 74 (2), p. 246-251.

1257 Quinif, Y., 1989. La notion d'étages de grottes dans le karst belge. *Karstologia*, 13, 41–49.

1258 Quinif, Y., 1999. Karst et évolution des rivières : le cas de l'Ardenne. *Geodinamica Acta*,  
1259 Elsevier, Paris, 12, 3-4, 267-277.

1260 Quinif, Y., 2006. Complex stratigraphic sequences in Belgian caves: correlation with climatic  
1261 changes during the middle, the upper Pleistocene, and the Holocene. *Geologica Belgica* [En  
1262 ligne], number 3-4 - Han-sur-Lesse Symposium - nov. 2004, 9, 231-244.

1263 Quinif, Y., 2010. Fantômes de roche et fantômisation. Essai sur un nouveau paradigme en  
1264 karstogénèse. *Karstologia Mémoires*, 18, 196 p.

1265 Quinif, Y. and Maire, R., 1998. Pleistocene deposits in Pierre-Saint-Martin cave, French  
1266 Pyrenees. *Quaternary Research*, 49, 37–50.

1267 Richard, M., C. Falguères, Pons-Branchu, E., Bahain, J.-J., Voinchet, P., Lebon, M., Valladas,  
1268 H., Dolo, J.-M., Paud, S., Rué, M., Daujeard, C., Moncel, M.-H., Raynal, J.-P., 2015.  
1269 Contribution of ESR/U-series dating to the chronology of late Middle Palaeolithic sites in the  
1270 middle Rhône valley, Southeastern France. *Quaternary Geochronology* 30, 529–534.

1271 Rixhon, G. & Demoulin, A. 2010. Fluvial terraces of the Amblève: a marker of the Quaternary  
1272 river incision in the NE Ardenne massif (western Europe). *Zeitschrift für Geomorphologie* 54,  
1273 161–180.

1274 Rixhon, G., Braucher, R., Bourlès, D., Siame, L., Bovy, B., Demoulin, A., 2011. Quaternary  
1275 river incision in NE Ardennes (Belgium) – insights from  $^{10}\text{Be}/^{26}\text{Al}$  dating of river terraces.  
1276 *Quat. Geochronol.* 6, 273–284.

1277 Rixhon, G., Bourlès, D.L., Braucher, R., Siame, L., Cordy, J.-M., & Demoulin, A., 2014.  $^{10}\text{Be}$   
1278 dating of the Main Terrace level in the Amblève valley (Ardennes, Belgium): new age  
1279 constraint on the archaeological and palaeontological filling of the Belle-Roche palaeokarst.  
1280 *Boreas*, 43, 2, 528–542.

1281 Rixhon, G., Briant, R.M., Cordier, S., Duval, M., Jones, A., Scholz, D., 2016 (in press).  
1282 Revealing the pace of river landscape evolution during the Quaternary: recent developments in  
1283 numerical dating methods. *Quaternary Science Reviews*.  
1284 Rodet, J., 1992. La craie et ses karsts. Centre normand d'étude du karst et des cavités du sous-  
1285 sol et Groupe Seine, Rouen, 560 p.  
1286 Rodet, J., 2013. Karst et évolution géomorphologique de la côte crayeuse à falaises de la  
1287 Manche. L'exemple du Massif d'Aval (Etretat, Normandie, France). *Quaternaire*, Paris, 24, 3,  
1288 303-314.  
1289 Rohling, E. J., Grant, K., Bolshaw, M., Roberts, A. P., Siddall, M., Hemleben, Ch., Kucera, M.,  
1290 2009. Antarctic temperature and global sea level closely coupled over the past five glacial  
1291 cycles. *Nature Geoscience* 2, 500 – 504.  
1292 Seranne, M., Camus, H., Lucazeau, F., Barbarand, J., Quinif, Y., 2002. Surrection et érosion  
1293 polyphasées de la Bordure cévenole. Un exemple de morphogenèse lente. *Bulletin Société*  
1294 *Géologique de France*, 173, 2, 97–112.  
1295 Stepišnik, U., Ferk, M., Kodolja, B., Medenjak, G., Mihevc, A., Natek, K., Žebre, M., 2009.  
1296 Glaciokarst of western Orjen, Montenegro. *Cave and Karst Science* 36 (1), 21-28.  
1297 Stock, G.M., Anderson, R.S., Finkel, R.C., 2004. Pace of landscape evolution in the Sierra  
1298 Nevada, California, revealed by cosmogenic dating of cave sediments. *Geology*, 32, 193-196.  
1299 Stock, G.M., Anderson, R.S., Finkel, R.C., 2005. Rates of erosion and topographic evolution  
1300 of the Sierra Nevada, California, inferred from cosmogenic <sup>26</sup>Al and <sup>10</sup>Be concentrations.  
1301 *Earth Surf. Process. Landforms*, 30, 985–1006.  
1302 Stokes, M., Mather, A. E., Harvey, A. M., 2002. Quantification of river-capture-induced base-  
1303 level changes and landscape development, Sorbas Basin, SE Spain. *Geological Society*,  
1304 London, Special Publications 191, 23-35.  
1305 Tassy, A., Mocochain, L., Bellier, O., Braucher, R., Gattacceca, J., Bourlès, D., 2013. Coupling  
1306 cosmogenic dating and magnetostratigraphy to constrain the chronological evolution of peri-  
1307 Mediterranean karsts during the Messinian and the Pliocene: Example of Ardèche Valley,  
1308 Southern France. *Geomorphology*, 189, 81–92.  
1309 Tassy, A., Fournier, F., Munch, P., Borgomano, J., Thion, I., Fabri, M.-C., Rabineau, M.,  
1310 Arfib, B., Begot, J., Beslier, M.-O., Cornée, J.-J., Fournillon, A., Gorini, C., Guennoc, P.,  
1311 Léonide, P., Oudet, J., Paquet, F., Sage, F., Toullec, R., 2014. Discovery of Messinian canyons  
1312 and new seismic stratigraphic model, offshore Provence (SE France): Implications for the  
1313 hydrographic network reconstruction. *Marine and Petroleum Geology*, 57, 25–50.



1314 Tognini, P., 1999. The Mt. Bisbino (Northern Italy) karst: a new speleogenetic process. Etudes  
1315 de géographie physique, supplément n° XXVIII [proceedings of the European Conference "  
1316 Karst 99 ", Grands Causses - Vercors, 10-15 September 1999], CAGEP, Université de  
1317 Provence, 185-190.

1318 Vergari, A. and Quinif, Y., 1997. Les paléokarsts du Hainaut (Belgique). *Geodynamica Acta*,  
1319 10, 4, 175–187.

1320 Vernet, J.-L., Mercier, N., Bazile F., Brugal, J.-P., 2008. Travertins et terrasses de la moyenne  
1321 vallée du Tarn à Millau (sud du Massif central, Aveyron, France) : datations OSL, contribution  
1322 à la chronologie et aux paléoenvironnements. *Quaternaire*, 19, 1, 3–10.

1323 Wagner, T., Fabel, D., Fiebig, M., Häuselmann, P., Sahy, P., Sheng Xu, Kurt Stüwe, 2010.  
1324 Young uplift in the non-glaciated parts of the Eastern Alps. *Earth and Planetary Science Letters*  
1325 295, 159–169.

1326 Waltham, A.C., Simms, M.J., Farrant, A.R. & Goldie, H.S., 1997, *Karst and Caves of Great*  
1327 *Britain*, Geological Conservation Review. Series, No. 12, Chapman and Hall, London, 358 p.

1328 Wang, F., Li, H., Zhu, R., Qin, F., 2004. Late Quaternary downcutting rates of the Qianyou  
1329 River from U/Th speleothem dates, Qinling mountains, China. *Quat. Research*, 62, 194– 200.

1330 Webb, J.A., Fabel, D., Finlayson, B. L., Ellaway, M., Shu,L., Spiertz, H.-P., 1992. Denudation  
1331 chronology from cave and river terrace levels: the case of the Buchan Karst, southeastern  
1332 Australia. *Geol. Mag.* 129, 3, 307–317.

1333 White, W. B., 1988. *Geomorphology and hydrology of karst terrains*. Oxford University press,  
1334 464 p.

1335 Whittaker, A. C., Boulton, S. J. (2012). Tectonic and climatic controls on knickpoint retreat  
1336 rates and landscape response times, *J. Geophys. Res.*, 117, F02024.

1337 Woodward, J.C., Hamlin, R. H. B., Macklin, M. G., Hughes, P. D., and Lewin, J., 2008. Glacial  
1338 activity and catchment dynamics in northwest Greece: Long-term river behaviour and the  
1339 slackwater sediment record for the last glacial to interglacial transition. *Geomorphology*, 101,1-  
1340 2: 44–67.

1341

1342

1343 **Figures**

1344 Figure 1: Location map of the karstic areas discussed in the text.

1345 Figure 2: Schematic diagrams of the relationships between valley evolution and karstification:  
1346 A) The concept of correlation between surface features (alluvial terraces) and subsurface  
1347 karstification levels (caves) (modified from Abel *et al.*, 2002); B) Different types of cave profile

1348 development, constrained by recharge (a and b) and base-level controls (c and d) (after Audra  
1349 & Palmer, 2011).

1350 Figure 3: Typology of the relationships between karst and valley incision, demonstrating the  
1351 type of speleogenesis, characteristic morphologies, and examples (after Losson, unpublished)

1352 Figure 4: Karst and entrenched valleys in the Eastern Paris Basin: A) Typology of the relations  
1353 between karstification and valley evolution; B) hydraulic gradient between aquifer  
1354 compartments and rivers (after Devos, unpublished).

1355 Figure 5: Idealised models of *per descensum* (A) and *per ascensum* (B) speleogenesis using  
1356 examples from the Vercors Subalpine Chain (A) and the Lower Ardèche River (B).

1357 Figure 6: Two conceptual models of gypsum karst: A: interstratal karstification with  
1358 contemporary underground erosion processes (after Calaforra & Pulido-Bosch, 2003); B: karst  
1359 subsidence and accelerated fluvial aggradation (after Benito *et al.*, 2010)

1360 Figure 7: A conceptual model of valley scale karstic and fluvial development in relation to river  
1361 terrace records: A) successive stages of evolution of a karstic drain and a valley floor, B)  
1362 schematic cross-section of relationships between cave passage and valley terrace during phase  
1363 4 (upstream part); C) Model elevation / time of the hydrographic network and the cave passage  
1364 (Jaillet, unpublished)

1365 Figure 8: Valley entrenchment during a Pleistocene glacial-interglacial cycle in limestone areas.  
1366 A: connected cave and base levels of a same valley (plateau karst); B) speleogenesis in connection with  
1367 an neighbouring valley (valley karst) (after Antoine, 1994; Losson, 2003; Antoine *et al.*, 2006; Quinif,  
1368 2006)

1369 Figure 9: Conceptual model of climate-driven speleogenesis of gypsum cave systems in relation  
1370 with valley incision and aggradation in moderately and rapid uplifted gypsum area: A) climate-  
1371 driven speleogenesis of epigenic gypsum cave systems, B) evolution of river valleys and  
1372 adjacent gypsum cave systems (based on the Northern Apennines after Colombu *et al.*, 2015)

1373

1374

1375

1376

1377

1378

1379

1380

1381 **Figure 1**

1382

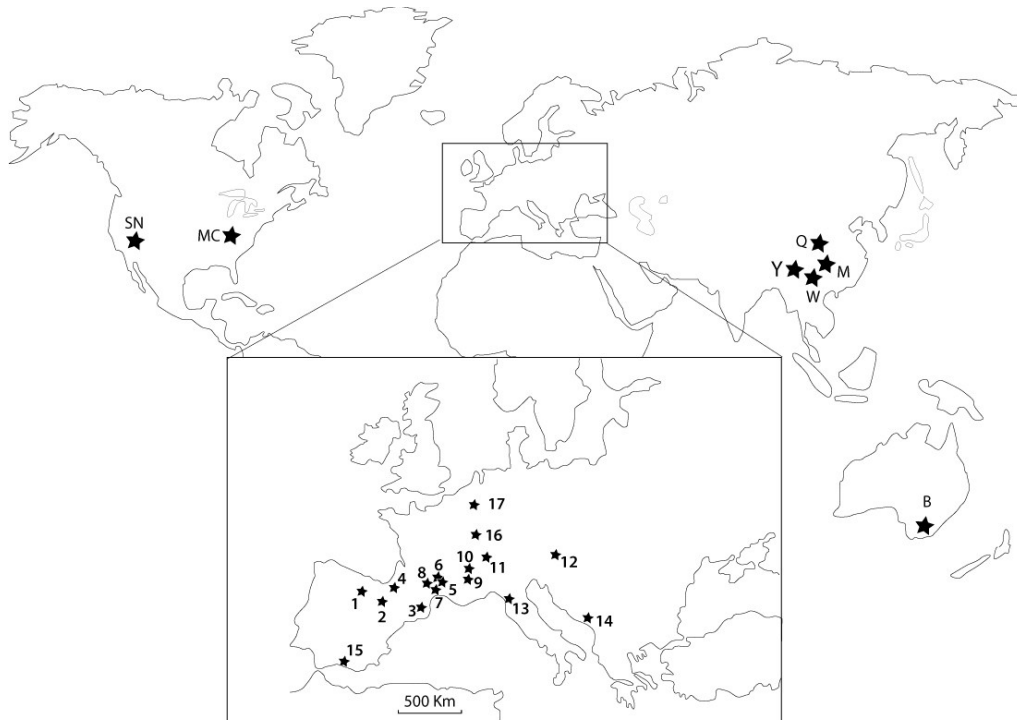

B: caves of Buchan, Australia; MC: Mammoth cave, USA; SN : Sierra Nevada, USA; M: Miaozi River, Hunan, China; Q: Qianyou River, Qinling mountains, China; W: Wujiang River, Guizhou, China; Y: Yangzi Gorge, Yunnan, China; Europe: 1: Arlanzón, Spain; 2: Gállego River, Spain; 3: Têt valley, Eastern Pyrenees, France; 4: Pierre-Saint-Martin, Western Pyrenees, France; 5: Lower Ardèche valley, France; 6: Middle Ardèche valley, France; 7: Southern Larzac plateau, Grands Causses, France; 8: Tarn valley at Millau, Grands Causses, France; 9: Vercors, subalpine massif, France; 10: Mont Granier, Grande Chartreuse, subalpine massif, France; 11: Siebenhengste, Switzerland; 12: Mur valley, Eastern Alps, Austria; 13: Monte Corcia, Alpi Apuane, Italy; 14: Mount Orjen, Montenegro; 15: Gypsum karst of Sorbas, Spain; 16: Caves of Pierre-la-Treiche, Eastern Paris Basin, France; 17: Cave of Belle-Roche, Ardenne massif, Belgium

1383

1384

1385

Figure 2

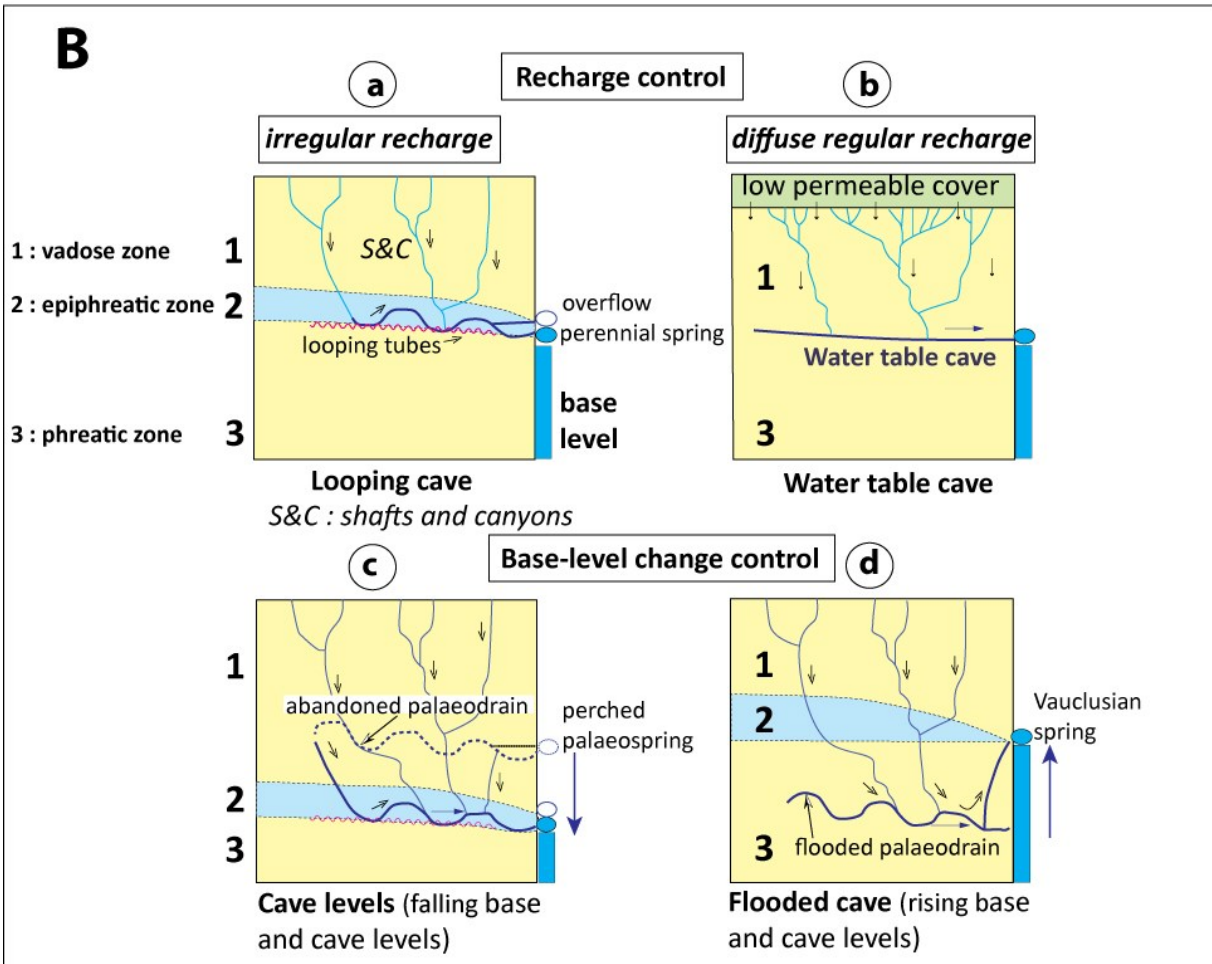
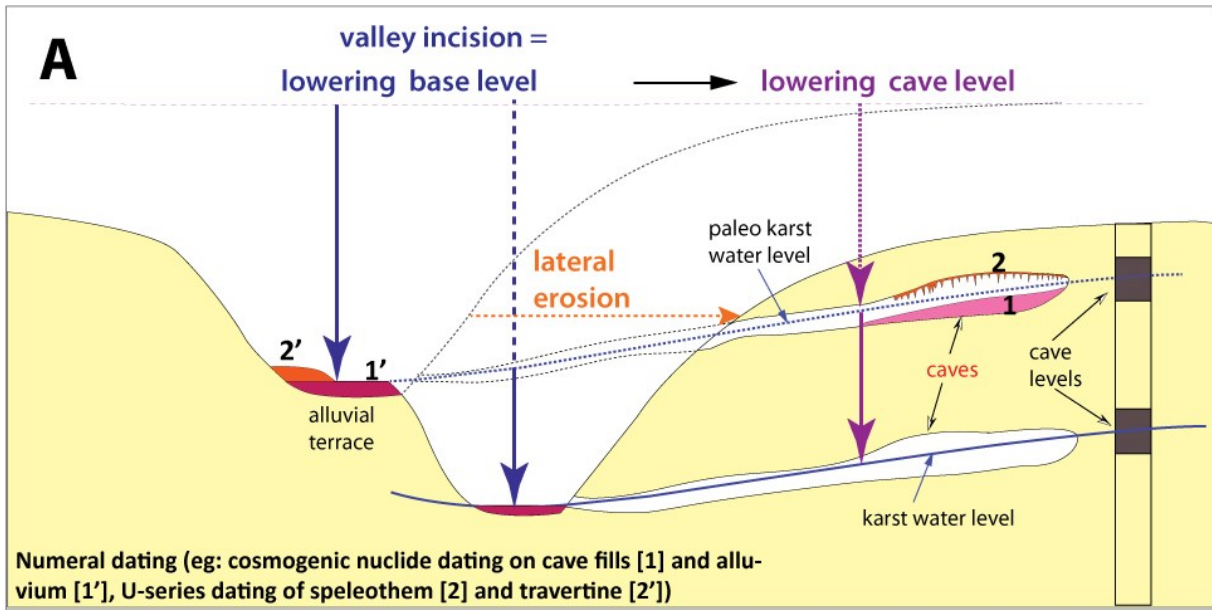
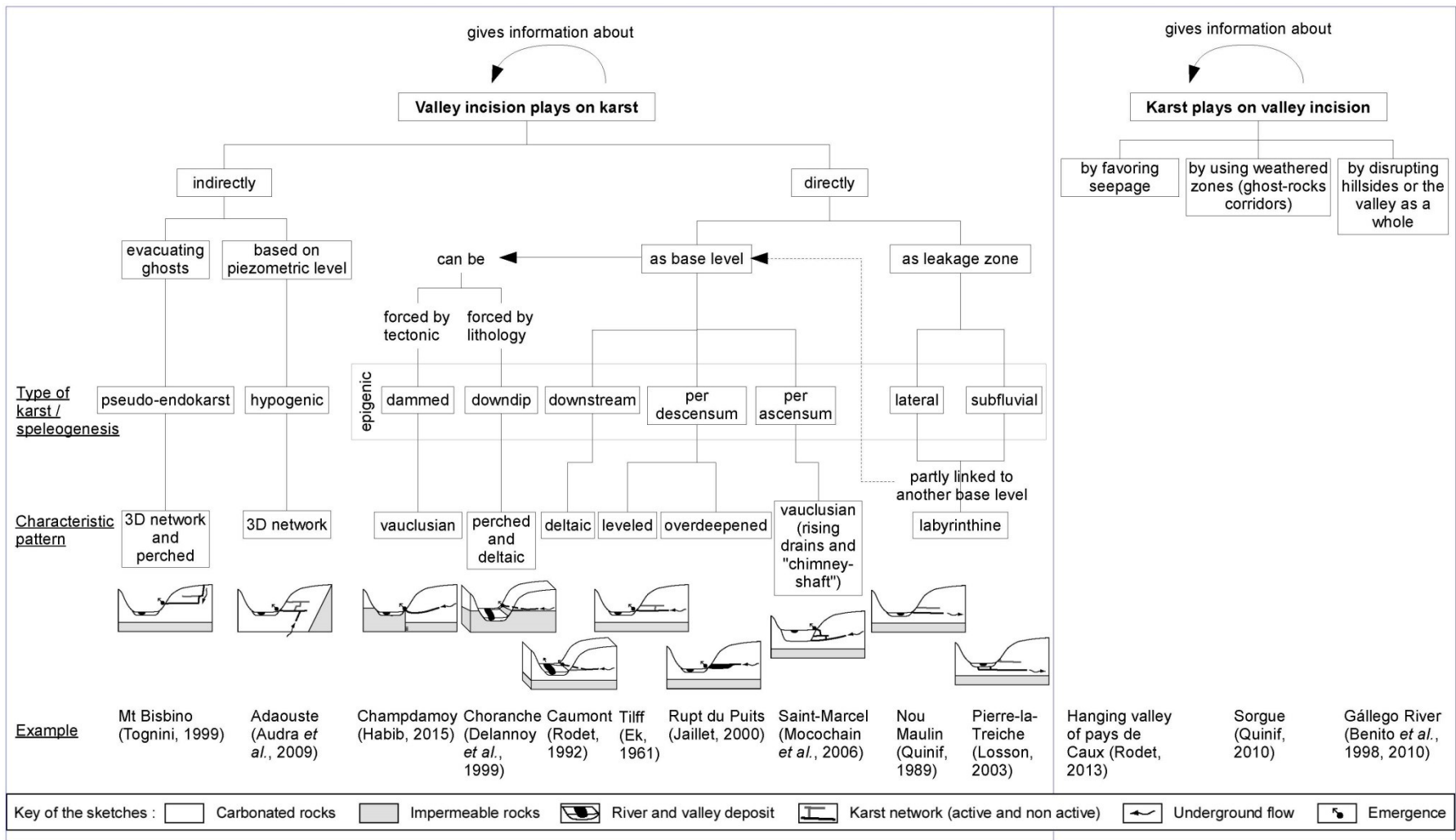
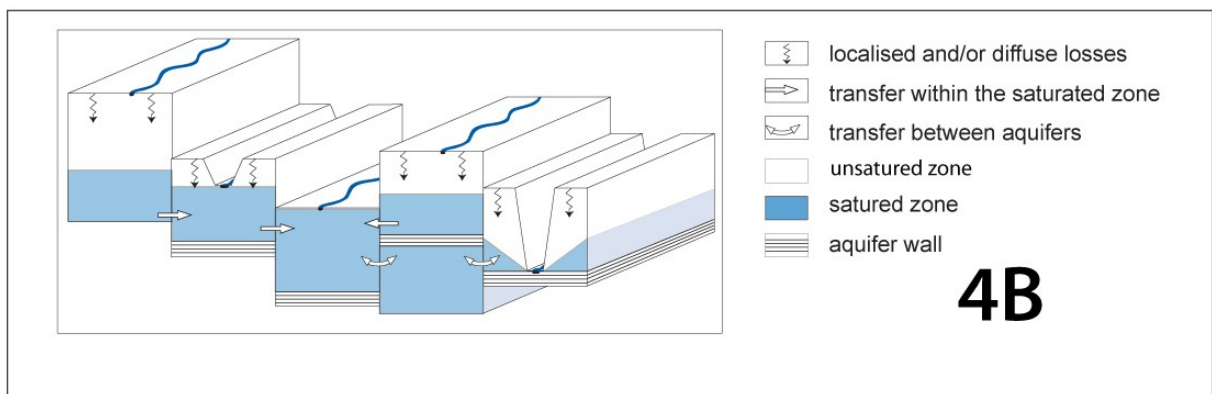
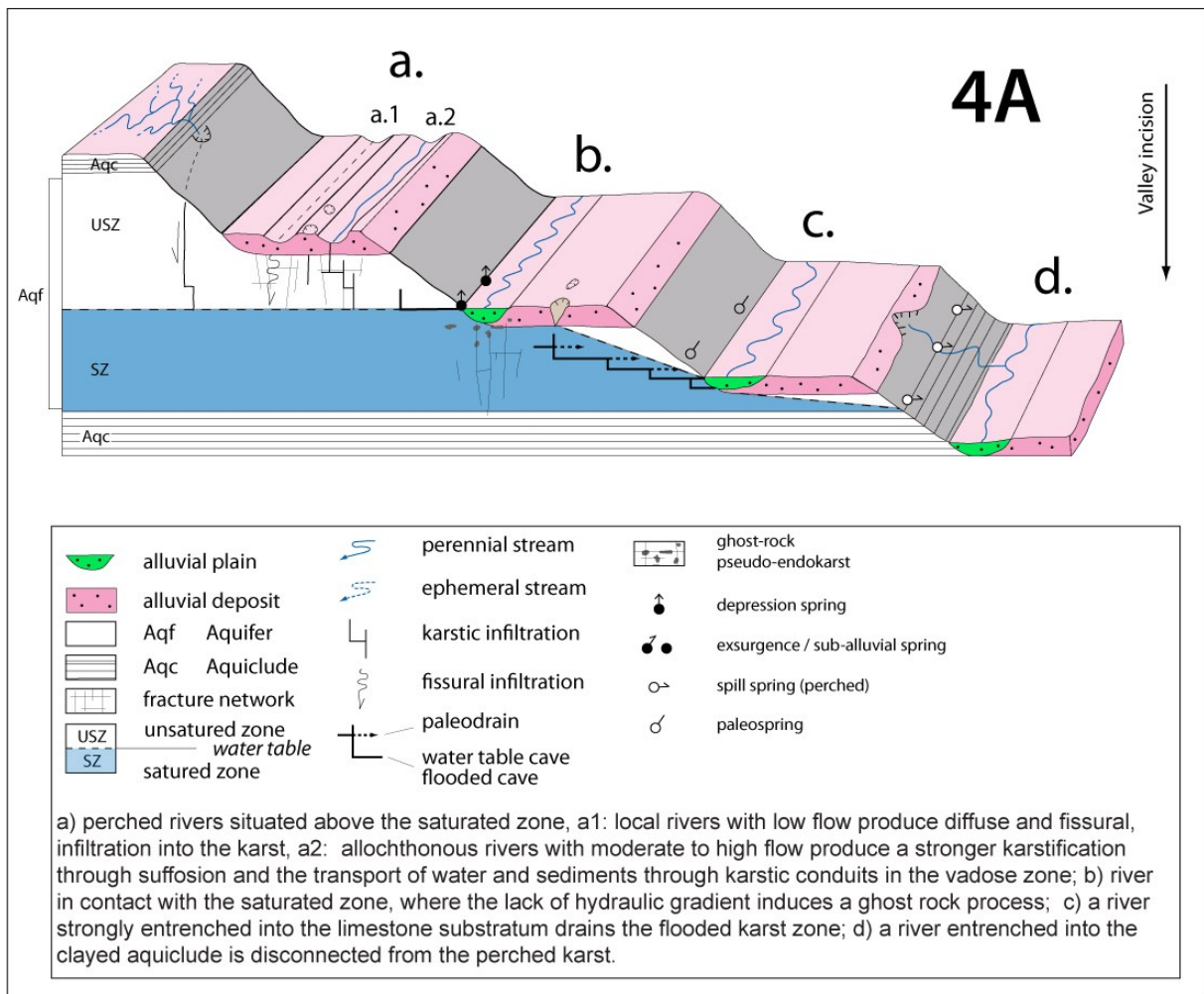

Figure 3



**Figure 4**



**Figure 5**

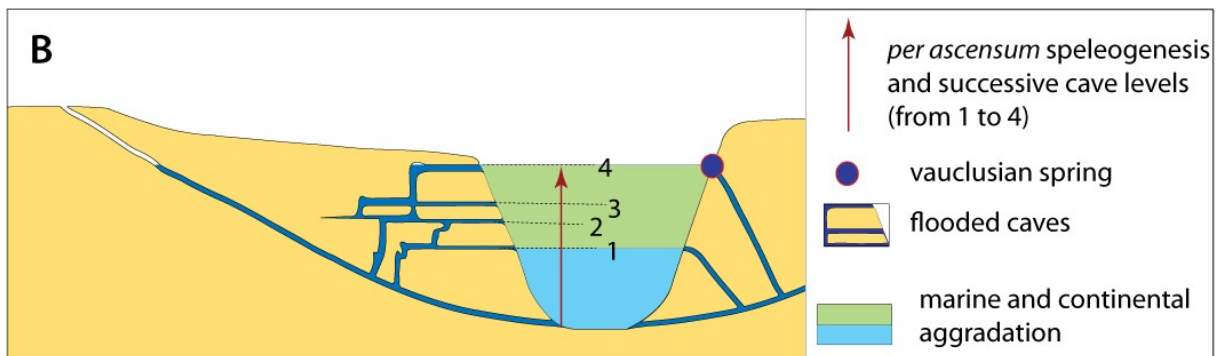
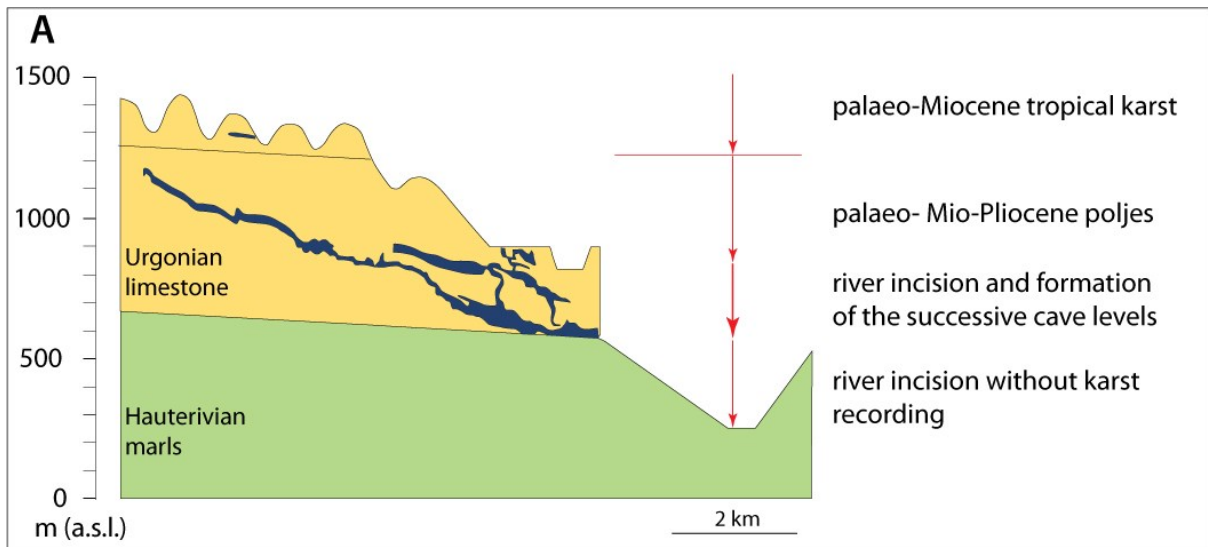

A: Per descensum speleogenesis incision in connection with uplift and valley incision (model of the Ver-cors subalpin chain, after Delannoy et al., 2009); B: Per ascensum speleogenesis : model of the Lower Ardèche river (after Audra & Palmer, 2011)



**Figure 6**

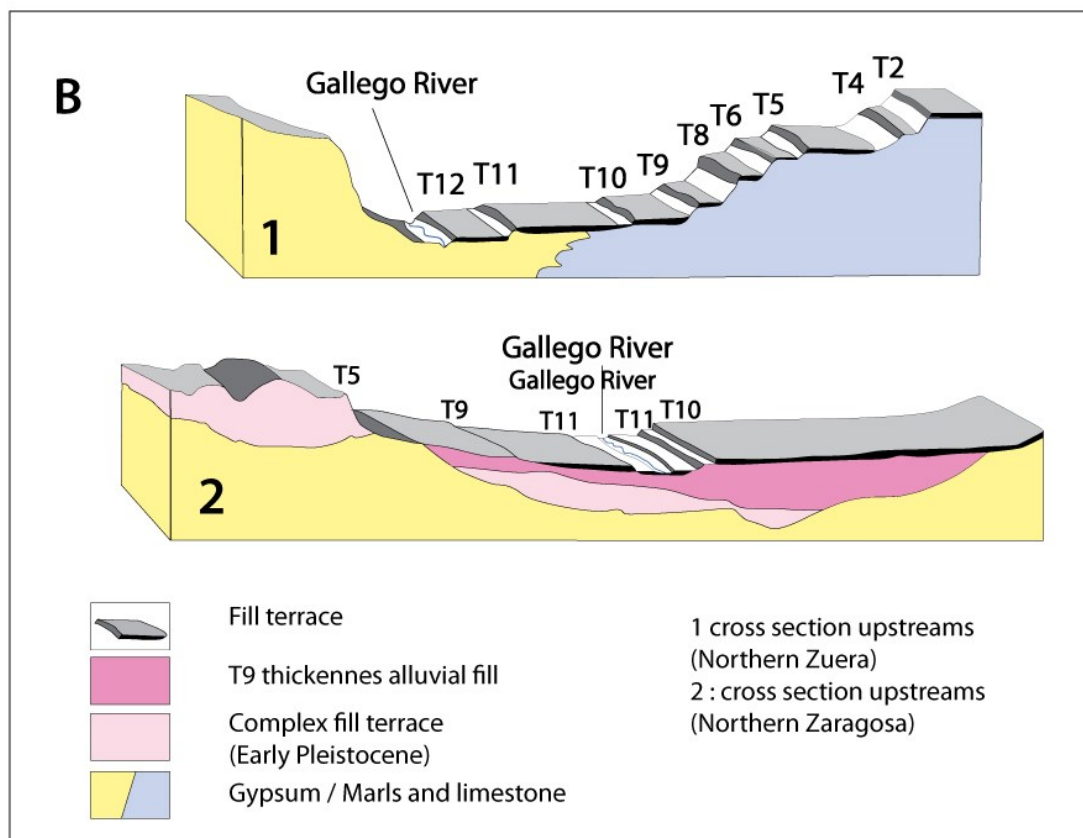
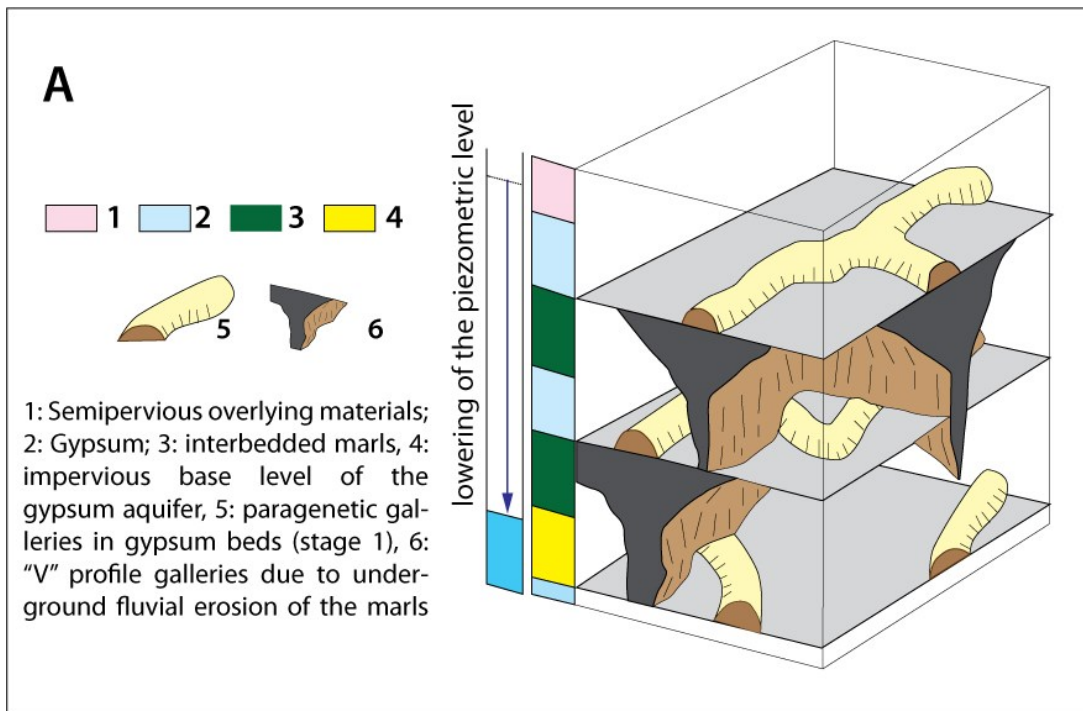



Figure 7

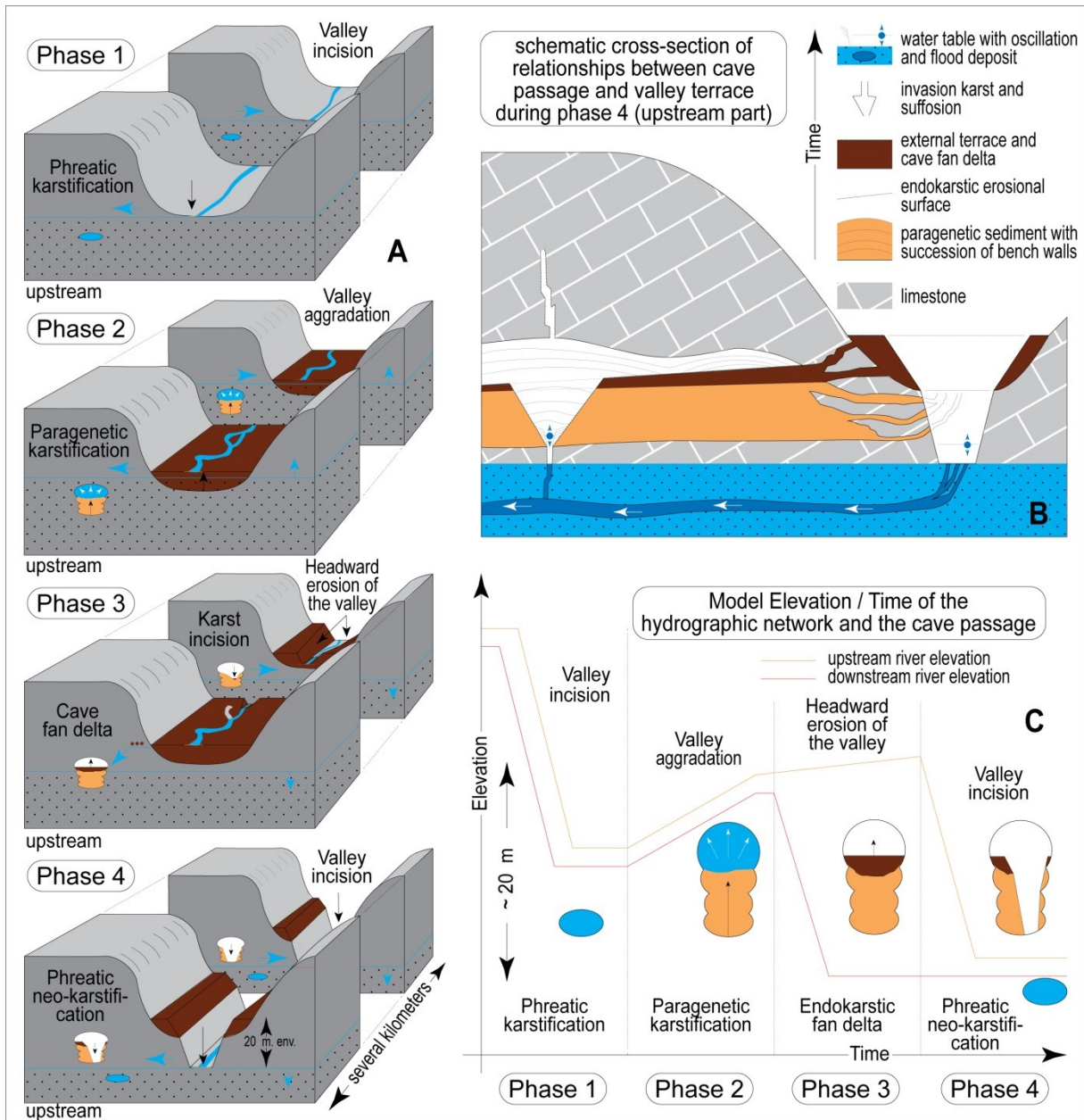

Figure 6

Figure 8:

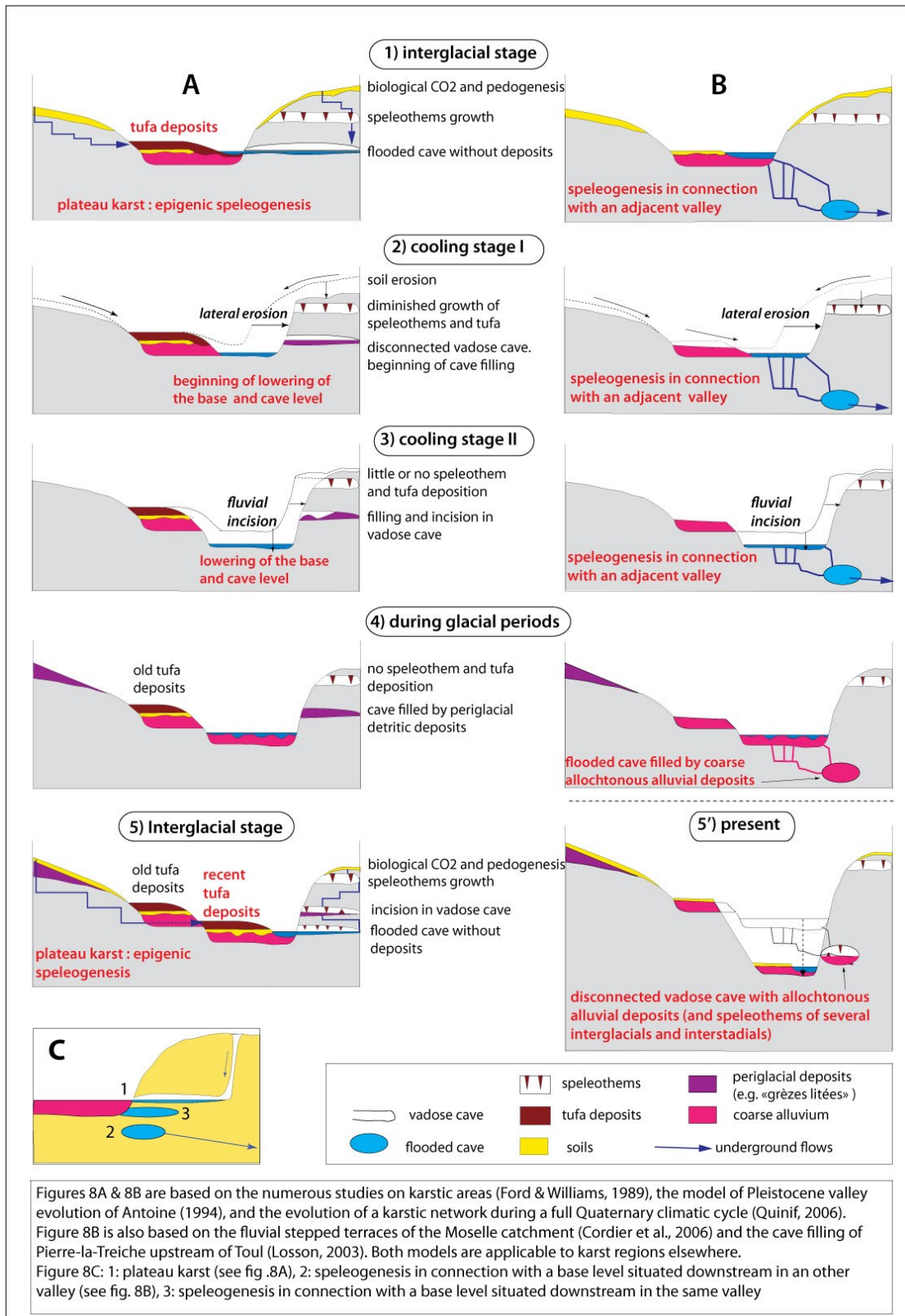

Figure 9:

