



**HAL**  
open science

# Innovative Vineyards Environmental Monitoring System Using Deep Edge AI

Marcello Coppola, Louis Noaille, Clément Pierlot, Rachel Ouviaha de Oliveira, Nathalie Gaveau, Marine Rondeau, Lucas Mohimont, Luiz Angelo Steffemel, Simone Sindaco, Tullio Salmon

► **To cite this version:**

Marcello Coppola, Louis Noaille, Clément Pierlot, Rachel Ouviaha de Oliveira, Nathalie Gaveau, et al.. Innovative Vineyards Environmental Monitoring System Using Deep Edge AI. Artificial Intelligence for Digitising Industry Applications, River Publishers, pp.261-278, 2021, 9788770226646. hal-03355270

**HAL Id: hal-03355270**

**<https://hal.univ-reims.fr/hal-03355270>**

Submitted on 28 Sep 2021

**HAL** is a multi-disciplinary open access archive for the deposit and dissemination of scientific research documents, whether they are published or not. The documents may come from teaching and research institutions in France or abroad, or from public or private research centers.

L'archive ouverte pluridisciplinaire **HAL**, est destinée au dépôt et à la diffusion de documents scientifiques de niveau recherche, publiés ou non, émanant des établissements d'enseignement et de recherche français ou étrangers, des laboratoires publics ou privés.



Distributed under a Creative Commons Attribution - NoDerivatives 4.0 International License

# 4.1

---

## Innovative Vineyards Environmental Monitoring System Using Deep Edge AI

---

**Marcello Coppola<sup>1</sup>, Louis Noaille<sup>2</sup>, Clément Pierlot<sup>3</sup>, Rachel Ouviaha de Oliveira<sup>3</sup>, Nathalie Gaveau<sup>4</sup>, Marine Rondeau<sup>4</sup>, Lucas Mohimont<sup>4</sup>, Luiz Angelo Steffene<sup>4</sup>, Simone Sindaco<sup>5</sup> and Tullio Salmon<sup>5</sup>**

<sup>1</sup>ST Microelectronics, France

<sup>2</sup>TechNext, France

<sup>3</sup>Groupe Vranken-Pommery, France

<sup>4</sup>University of Reims Champagne-Ardenne, France

<sup>5</sup>Alma Mater Studiorum - Università di Bologna, Italy

### Abstract

With a turnover of more than 4.2 billion euros in 2020 and a 20% share in the value of the French wine industry's exports, the champagne industry represents a considerable weight in the French economy. In this context of significant economic development, the issue of climate change has been added, calling into question the practices and means of production of the sector. The challenges related to global warming and an ever-increasing demand for yield can be addressed using the Internet of Things (IoT) and Artificial Intelligence (AI) technologies to benefit champagne production and answer these challenges.

This article presents a solution to optimise Vranken Pommery products' quality and make environmentally friendly decisions by using intelligent sensors distributed as close as possible to the production and storage facilities to collect data. These sensors use LoRaWAN technology and protocol to communicate. The system integrates components capable of hosting artificial intelligence algorithms and using advanced microcontrollers that allow for intelligent communication network implementation while reducing power consumption and deployment costs.

**Keywords:** artificial intelligence, internet of things, AI-based microcontrollers, deep edge AI, LoRaWAN, vineyards, champagne.

### 4.1.1 Introduction

The 21st century has brought a digital transformation in the industrial sector in which the boundaries between the physical and digital worlds are blurring to create what we called Industry 4.0. Industry 4.0 will be the place where employees, machines and products interact, bringing a new set of technologies to enable the Internet of Things (IoT) and, more specifically, the Industrial Internet of Things (IIoT).

Industry 4.0 began in manufacturing but has become essential for all industrial markets such as the food and beverage markets. Like any business, those within food and beverage manufacturing, such as Champagne manufacturers, must respond quickly and effectively to change to keep up with competitors. Industry 4.0 applied to Champagne is a challenge since today the work in vineyards in Champagne still involves many manual tasks such as counting grape berries for yield forecasting or visual inspection of vines for disease detection. These tasks are essential because the quality of Champagne naturally depends on the quality of the raw material, i.e., grapes. In addition to the agricultural imperatives, the Champagne is the result of a long and rigorous industrial manufacturing process, as shown in Figure 4.1.1. This process starts with the pressing and the first fermentation, continues with the assembly and the second fermentation, the ageing in the cellar, and ends with bottling and sending to the end customer.

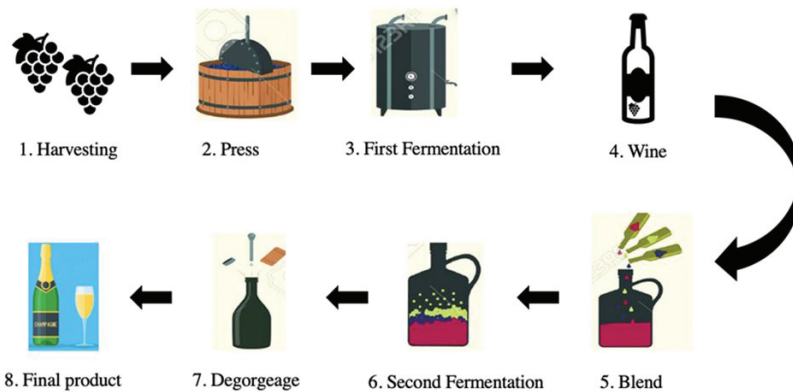

**Figure 4.1.1** Value chain for champagne production.

Smart manufacturing leveraging on IoT and Cyber-Physical Systems (CPS) enables different physical sensors, actuators, and controllers to be locally interconnected and globally connected to cloud computing servers, forming complex online systems.

The use of IIoT can have an impact all along the manufacturing process of champagne (and more generally of wine). Indeed, thanks to sensors distributed in vineyards, it is possible to collect numerous data such as humidity, temperature or soil parameters: moisture, temperature, and electrical conductivity. The analysis of these data helps winemakers better managing and controlling the growth of their cultures. Besides, with the help of AI, specialised analytics allow growers to continually monitor soil, plant, and atmosphere to adjust irrigation and fertilisation in response to the environment. For example, by comparing current data with historical ones, the creation of predictive models on the best harvest period is now a reality. Furthermore, beyond the vineyard itself, IIoT can be used in wine cellars to monitor the ageing and the conservation of the champagne. Temperature is particularly important as even slight fluctuations impact the oxidation of the wine, which strongly affects the quality. Thanks to the IIoT, vintners are able to understand when tiny fluctuations occur and correct them before any damage is done. Thus, IIoT can help winemakers to achieve more successful harvests, better control production, and ensure ideal quality during transit and storage.

With these ideas in mind, this article presents a new environmental monitoring system enhanced by AI for yield forecasting, disease detection, fertiliser/pesticide optimisation, quality estimation, etc. This document aims to explain how the solution works, from the communication part to the intelligence part, and give insights on how this solution will help champagne manufacturers.

The article is structured as follows. Section 4.1.2 describes the current state of the art. Section 4.1.3 introduces the edge intelligence concept. Section 4.1.4 describes the LoRaWAN system architecture. Section 4.1.5 presents the monitoring system along with the architecture of the end nodes enhanced by AI. Section 4.1.6 concludes the work.

## **4.1.2 Related Work**

Agriculture is seeing fundamental changes due to IoT and AI. In today's global warming environment and growing demographics, connected objects and artificial intelligence are an advantage. Their use allows farmers to

manage their farms better. Collecting data on the state of crops, weather forecasts, or even parameters such as temperature or humidity is at the heart of the intelligent farming concept.

The main contribution of AI and IIoT in agriculture is helping the industry players make decisions, allowing them to optimise their production and, therefore, their yield. For example, Farmwave [1] will enable farmers in the decision-making process concerning their farms. Using vision-based algorithms and edge AI, this solution can identify pest damage and disease through photos. Plantix [2] is also a solution to help farmers and agricultural workers increase their productivity. Thanks to a mobile application, farmers can take pictures of their crops and get information about them. Plantix can diagnose infected crops and diseases and propose appropriate treatments.

Unlike solutions such as Farmwave or Plantix, which rely on images, some use data collection and AI to provide models and predictions to help farmers know how to optimise the productivity of their crops. This is the case of CropX [3], a solution that measures moisture, temperature, and electrical conductivity in the soil. CropX helps farmers monitor their crops and ensure increased productivity by providing crop-specific recommendations. Thanks to AI, CropX uses crop models to learn and understand the behaviour of its supported crops, depending on the region. CropX also provides aerial imagery, topography maps, and soil mapping to help the farmer in the decision-making process.

Another example could be Microstrain [8] which is a wireless environmental detection system that monitors vineyards' key growth episodes. Information such as soil and leaf moisture, solar radiation and temperature are collected and merged to monitor vineyards remotely and alert growers to critical situations.

In addition to providing an answer to purely economical questions, AI and IoT are being used to provide solutions to more complex problems. Adapting production methods to climate change is, for instance, one of the challenges of smart agriculture. The solution aWhere [7] uses AI to give insights about the weather to help farmers, companies, governments, or agencies adapting to climate change. More than 1.9 million virtual weather stations are deployed to turn climate insights into action (as pest and disease modelling, fertiliser timing recommendations, optimal planting dates, etc.) and create powerful maps to monitor the weather in a specific area (global to local scale).

The issues raised by the concept of sustainable development also integrates a social dimension, and some solutions try to respond to this

problem. For example, PlantVillage Nuru [4] helps farmers from developing countries diagnose crop diseases, even without an internet connection. Developed with the UN FAO (Food and Agriculture Organization of the United Nations) and the CGIAR (Consultative Group on International Agricultural Research), Nuru is an AI assistant that can diagnose multiple diseases in Cassava, fall armyworm infections in African Maize, potato disease and wheat disease. An essential part of the PlantVillage Nuru solution is also the share of knowledge between smallholder farmers.

Many projects belonging to smart farming concept are based on servomechanism systems such as robots, drones, or satellites rather than scattered sensors. For example, Precisionhawk [5] is a solution based on drones, sensors, and AI. Drones collect high-quality data through sensors to survey, map, and image farmland. The results are then provided to a web application.

The Blue River Technology project [6] has developed robots that can accurately distinguish between “weeds” and cultivated plants using AI. Based on image processing algorithms, this solution allows farmers to limit spraying to weeds only, thereby reducing pesticide use.

Finally, Taranis [9] helps farmers monitor their fields. Using satellites, planes, and drones with vision-based AI, this solution allows workers to detect and prevent crop loss due to insects, crop disease and weeds. Data are assembled in reports, graphs, maps, or insights to make the decision-making process easier for the worker.

### **4.1.3 Edge Intelligence**

AI has started to widen the application potentiality of IoT and CPS, enriching them with intelligent services used by many users. Deployment of standalone localised CPS such as the one offered by the ISA-95 model based on supervisory control and data acquisition (SCADA) system offers an inefficient solution due to resource wastage, prohibitive costs with the significant disadvantage of the distributed system nature of data itself. Thus, centralised approaches based on the cloud have tried to address these problems by combining data distribution and robust central services. A significant number of sensor data can be analysed and consolidated in synthetic format by modern dashboards. In these approaches dashboards are updated in real-time or near real-time to understand the adequate status of manufacturing processes better.

Compared to the previous approaches, cloud-based solutions enable to monitor the actual working conditions of machines and analyse data to understand what is happening. When deviations occur, using this approach, it is possible to identify the reasons for variation compared to a standard procedure. This transparency implies the possibility of subsequent forecasting events and thus anticipating possible dangerous situations for the efficiency of the manufacturing production lines. To implement an efficient correct forecast, it is important to analyse a considerable amount of data collected during a long period. Then, applying AI with the most appropriate ML algorithms that model the behaviour of machines, it is possible to anticipate the future event of the machines and decide the most appropriate actions. For instance, depending on these events, it is possible to predict the time of preventive maintenance. Another advantage of these cloud-based approaches is implementing the digital twin of one machine or an entire manufacturing line, enabling without human controls to activate the most appropriate corrective actions within the manufacturing process. Cloud-based monitoring solutions allow for the improvement of the operative efficiency of a manufacturing line by decreasing machine downtime and reducing maintenance periods. The core of the cloud-based monitoring system is to have an efficient communication infrastructure for each machine and the overall manufacturing line. Such communication infrastructure must send efficiently data coming from the sensors towards the cloud. Cloud-based monitoring systems require smart sensors that include functionalities of communication and data signal processing.

Data signal processing is required to transform the physical monitored variable into something meaningful that can be transmitted to the cloud. For such reasons nowadays, such sensors include Micro Controller Unit (MCU), analogue and digital interfaces, memories, and communication hardware. The degree of smartness is related to its decentralised computation capabilities to perform operations that may include data from many probes connected to the same smart sensors. Considering the Moore law, it is possible to implement smart sensors with smaller and more powerful MCUs such as the STM32.

These MCUs can process data from several probes and apply algorithms more and more complex, including AI. A direct implication of this trend is that smart sensors are becoming the hub of many probes, thus reducing the costs associated with communication, processing, latency, and energy.

Communication costs can be reduced since data can be combined, so less data will be transmitted. Reducing data communication also implies a reduction of energy since most of the energy of the end node is consumed

during the data transmission. Time-critical applications imply real-time/near-real-time computation. These requirements cannot be met using the standard cloud approach due to the broad latency introduced by the network. With the increase of computation, it is now possible to move part of the computation from the cloud to the smart sensors: aka the edge nodes.

Moving computation to the edge, we also address privacy and security. Data privacy is guaranteed since the MCU can now decide the form of data to be transmitted to the cloud. Instead, the security will be reinforced leveraging the hardware security mechanisms provided by modern MCU. Several research papers focused on the possibility of bringing artificial intelligence to devices with limited resources [13][14][15][16]. To bring an AI model to MCU, ML developers should deal with the proper hardware, ML accelerator and memory set up to fit with the limited resources.

Therefore, to implement ML, two solutions may be used. The first one is called on-device computation, where Deep Neural Networks (DNNs) are executed on the end device with no AI on the cloud. The second is referred to as hierarchical computation, where DNNs are executed on the device and then on the cloud. In the second solution, the DNNs executed on the device and the cloud are complementary. Implementing an AI algorithm on MCU is challenging. And it is still a young technology.

As a result, engineers often must rely on a lot of different tools and complex workflows. For such reason, tools are essential. An example of a good tool that enables simple implementation of a DNN on a MCU is the X-CUBE-AI [17], suitable only for STMicroelectronics MCUs. It is an expansion of the STM32CubeMX environment that extends the tool's potential, allowing an automatic conversion of pre-trained NNs to low resource hardware. X-CUBE-AI also optimises libraries by modifying layers and reducing the number of weights to make the network more memory friendly.

#### **4.1.4 Communication Technology – LoRaWAN**

The numerous IoT applications impose constraints on the choice of the network architecture to be implemented. Depending on the use of a connected object, the organisation of the communication network will be different. To meet the required specifications and use cases, a network using IoT must find a compromise between the following four constraints:

- Range



- Data transmission rate
- Power consumption
- Cost of deployment

There are many different technologies available for this purpose. If the communication must be done over short distances (a few metres to a hundred metres), it is possible to use Wi-Fi, Bluetooth, RFID or Zigbee connectivity. These technologies allow sending data at a fast rate with reasonable energy consumption, but the communication can only be done at short range [10].

If the use case requires sending data over a hundred metres, then cellular connectivity technologies (2G, 3G, 4G or 5G) seem more appropriate. Cellular technologies allow for the transmission of large amounts of data over vast distances, which can be advantageous in the industrial sector.

However, there are IoT use cases where these technologies are not adapted. Indeed, these technologies are energy-intensive and have a high deployment cost. In some applications, such as in the field of connected agriculture or smart cities, the connected devices used need to transmit little data over large distances but are powered by simple batteries that do not provide much energy [10].

LPWAN (Low Power Wide Area Network) technologies are designed to transmit over large distances and maintain sound signal propagation even in more challenging environments. In an open environment, communication can be established over several tens of kilometres. In a more constrained environment (e.g., in urban areas), the range of LPWAN technologies is a few kilometres. LPWANs consume very little energy and allow devices to reach a lifetime of 10 years or more depending on the battery used. In addition, LPWANs allow covering a large area with few communicating devices. Indeed, the long range of LPWAN technologies and the network structure itself allows deploying fewer devices than cellular technologies while maintaining optimal efficiency.

Finally, since LPWANs do not have to handle complex waveforms (such as a voice call, for example), the transmit/receive module does not have to be very elaborate, which saves on hardware and production techniques.

Thus, the exponential growth of the IoT and the possibilities offered by LPWAN technologies are very interesting for enterprises.

The number of deployed connected objects (excluding phones, tablets, and computers) was indeed 7 billion in 2018 and is expected to reach 21.5 billion in 2025. Of all these devices, 25% belonged to LPWAN deployments [10].

Therefore, some companies have invested in establishing LPWAN networks and offer their own technology solution.

The Figure 4.1.2 summarises the characteristics of different communication technologies [11][12].

The LoRaWAN protocol was born under the impetus of the LoRa Alliance, which brings together various players in the IoT. It allows realising an LPWAN network that benefits from the advantages of LoRa technology while providing a solution to some IoT requirements, such as mobility and a large capacity of module connections.

The LoRaWAN uses a star-of-stars topology in which gateways relay messages between LoRa modules and a LoRa server. Figure 4.1.3 shows the overall architecture of a LoRaWAN network, which can be broken down into four parts.

The *End Nodes* part groups all the LoRa modules that communicate with the gateways. These are the ones that contain all the sensors necessary for data acquisition. They have a LoRa radio that allows them to send the collected data to all the gateways within the communication range. The data transmission is done using LoRa technology.

The *Concentrator/Gateway* part gathers all the gateways that have been deployed. They ensure the link between the connected devices and the LoRa server. They listen to all the communication channels. They convert LoRa frames into messages understandable by the server and vice versa. They can handle many LoRa modules, giving the LoRaWAN network a high load capacity.

The *Network Server* receives, via TCP/IP communication, the messages transmitted by the LoRa gateways. It also manages incoming and outgoing

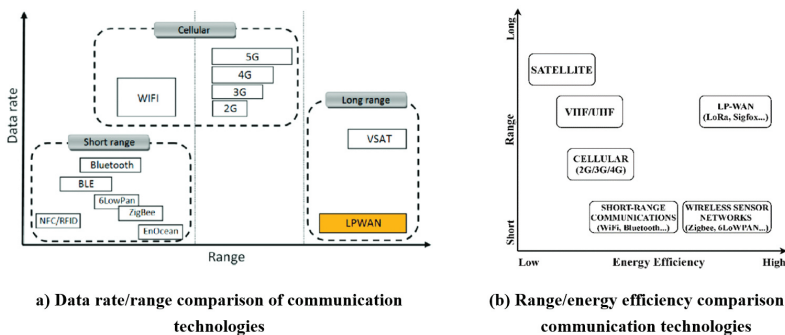

**Figure 4.1.2** Comparative range, data rate, energy efficiency characteristics of communications technologies [11][12].

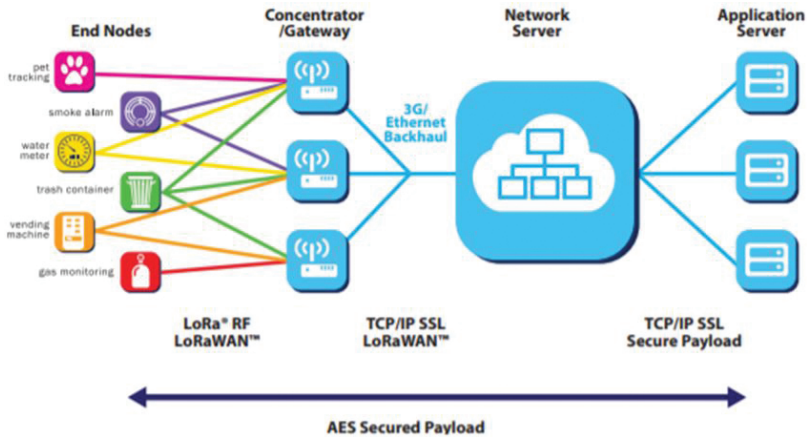

**Figure 4.1.3** LoRaWAN architecture [19].

communications between the application part of the network and the gateways. For example, it will delete messages received in duplicate (several gateways can send the same data if they are in the range of the same LoRa node) and will take care of the authentication of data sent and received by LoRa nodes.

The *Application Server* takes care of the encryption and decryption of messages passing through the network. In most cases, the Application Server is followed by a Web Application part, grouping the web applications that will use the data collected by the LoRa modules. This part does not belong to the LoRaWAN protocol and is implemented by the user, but one of the roles of the Application Server is to dissociate the different web applications that want to connect to the network and transmit the instructions coming from them to the LoRa terminals.

Communication within a LoRaWAN network is bidirectional. It can be uplink (from the terminals to the server) or downlink (from the server to the endpoints). Most transmissions in a LoRaWAN network are uplink. It is also possible to realise a LoRaWAN network implementing only uplink connections to reduce the complexity of the network if the use case allows it.

In addition to the energy benefits of LoRa technology, the LoRaWAN protocol has implemented a class system to reduce network consumption. Thus, a LoRa module can be class A, B or C depending on its ability to communicate in the downlink as presented in Figure 4.1.4.

All LoRa devices must be able to implement class A. This mode is the least power consuming. At each transmission of the terminal, two reception windows are opened to receive downlink communications.

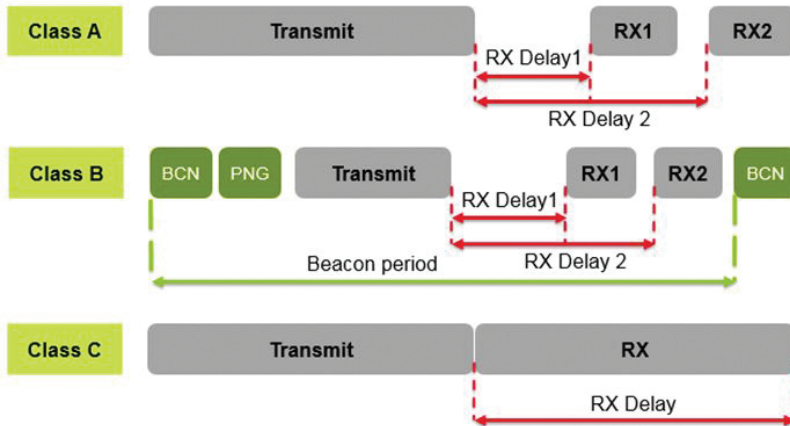

**Figure 4.1.4** Operation of the different classes of a LoRaWAN [18].

These reception windows depend on a fixed duration, frequency, and data rate. If the device receives communication in the RX1 window, then the second window is not opened, and the device goes back to standby.

A downlink communication can only be done after an uplink transmission has been done. This mode consumes very little energy, as the device is mainly on standby but imposes a significant gateway/module communication latency.

Class B is a mode that seeks a compromise between energy consumption and downlink communication latency. It has the same operation as class A (2 reception windows after each transmission) and implements reception windows that open periodically. To allow synchronising the reception windows between the LoRa module and the concentrator, the concentrator must send a beacon and a ping. The LoRa device can therefore receive instructions without having first sent a message. This mode reduces the latency of downlink communications but increases the terminal's power consumption.

Class C is a mode adapted to specific LoRa modules. Indeed, in this mode, the terminal continuously listens to downlink communications, except when it transmits. Class C eliminates any latency in the transmission but is not energetically viable for a battery-powered device. It is, therefore, suitable for modules connected to the mains.

One of the major drawbacks of LoRa technology is the lack of means to secure communication. The LoRaWAN protocol offers a solution to overcome this problem. Any communicating object wanting to join a network

must be identified. To achieve this identification, it is necessary that the device is activated.

The security within a LoRaWAN network is ensured using three essential elements:

- Device Address (DevAddr): address of the device on the network, acts as an IP address
- Network Session Key (NwkSKey): AES128 key shared between the terminal and the Network Server, used for authentication
- Application Session Key (AppSKey): AES128 key shared between the terminal and the Application Server, used for data encryption
- Each module knows three elements necessary for its identification by the LoRa server:
  - Device EUI (DevEUI): defines the device ID
  - Application EUI (AppEUI): defines the ID of the application to which the device is attached
  - Application Key (AppKey): a key that allows deriving the security keys

The transmission data rate depends on two parameters: the Spreading Factor (SF) and the Bandwidth (BW). The LoRaWAN protocol normalises the associations of these two parameters and names Data Rate (DR) an SF/BW pair. LoRaWAN lists seven DRs (from DR0 to DR6) for a LoRa modulation.

As the LoRaWAN protocol is based on LoRa technology, communication is carried out in the same frequency bands (from 863 MHz to 870 MHz in Europe). The LoRaWAN server defines several channels that can be used for uplink and downlink communications within this band. The LoRaWAN protocol requires the LoRa device to know the channels 868.1 MHz, 868.3 MHz, and 868.5 MHz from DR0 to DR5. LoRaWAN protocol also implements an algorithm named Adaptive Data Rate (ADR) that allows the Network Server to automatically calibrate the optimal DR for communication with the device, using *Signal to Noise Ratio* (SNR) and *Received Signal Strength Indication* (RSSI) [20].

Thus, LoRaWAN provides a suitable answer to most of the issues raised by the IoT. Its range of several kilometres, its energy efficiency and the robustness of its communications make LoRaWAN one of the most used solutions in the LPWAN market. The Table 4.1.1 summarises the characteristics of different LPWAN technologies.

**Table 4.1.1** LPWAN technologies comparison.

	<b>Sigfox</b>	<b>LoRaWAN</b>	<b>NB-IOT</b>	<b>LTE-M</b>
Modulation	UNB, GFSK	CSS	QPSK	16QAM
Flow	100 bps <i>uplink</i> 600 bps <i>downlink</i>	0,25 to 50 kbps	100 kbps	1 Mbps
Range (open environment)	To 50 km	To 20 km	To 10 km	To 5 km
Cost	€	€€	€€€	€€€
Lifetime	More than 10 years	More than 10 years	To 10 years	Less than 10 years
Payload (Bytes)	12 <i>uplink</i> 8 <i>downlink</i>	Up to 250	1600	More than 1000
Security	None	AES128	LTE	LTE
Quality of Service	None	Definable but complicated	Definable	Definable
Latency	<i>Downlink</i> communication limited	Depends on the class used	1 second	10 milliseconds
Mobility and localization	No	Yes	Limited mobility, no localization	Mobility, no localization
Deployment	Sigfox operator	Private operators and networks	Operators	Operators

## 4.1.5 Environmental Monitoring System

It is widely recognised that the digitalisation of French wine and champagne grape production can bring significant economic, environmental, and social benefits. The future of the Champagne and Wine sector implies an exponential increase to observe and monitor key aspects of production cost effectively. For a company like Vranken Pommery, the production starts at the vineyards and ends at the bottling. At each step, the data sources are diverse, spanning from simple environmental data to complex images. The environmental monitoring system manage the production operations and to reduce the waste by improving Vranken-Pommery operational efficiency.

Fungi cause the most common vine diseases. Different species can infect grapevines. Black rot (*Guignardia bidwellii*), Powdery mildew (*Uncinula necator*), and Grey mold (*Botrytis cinerea*) are examples of diseases that can affect grape quality. Each fungus develops under certain environmental conditions.

The environmental monitoring system is based on data collected by different industrial sensors (e.g., TEROS, STMicroelectronics, etc.) connected to STM32WL enhanced by a machine learning core enabling continuous monitoring of the environment, the soil, meteorological conditions, and/or plant performances. The STM32WL System-On-Chip integrates both a general purpose microcontroller and a sub-GHz radio on the same chip. Built on Arm® Cortex®-M4 and Cortex®-M0+ cores (single- and dual-core architectures available), STM32WL microcontrollers support multiple modulations- LoRa®, (G)FSK, (G)MSK, BPSK - to ensure flexibility in wireless applications with LoRaWAN®, Sigfox, W-MBUS, mioty® or any other suitable protocol in a fully open way. Sensors will be able to acquire and merge underground and climate data. Many sensors are today available on the market but in order to accurately understanding the percentage of water in a soil has been a complex, costly, and laborious process. Soil moisture is highly variable over short distances, at different depths in the soil profile, and in different soil types and densities. Today only few of sensors provide the right degree of precision and low percentage of sensor-to-sensor variability in their measurements. In the environmental monitoring system in order to meet the functional and not functional requirements provided by Vranken-Pommery for the soil moisture sensors, the TEROS12 sensor from METER Group has been selected since it provides sensor-to-sensor variability (less than 1%), at a reasonable cost. Thus, the TEROS12 sensors along with other types of sensors are used to make precise, informed decisions and better manage Vranken-Pommery, labour, equipment, and chemical usage. Technological advancements introduced by the STM32WL enables ML and efficient communication directly at the edge. To improve the power efficiency an innovative approach has been chosen: to enrich with a machine learning core to the STM32WL. The adopted solution give the possibility to implement ML directly to the STM32WL and/or to the machine learning core. The Machine Learning Core provided by the LSM6DSOX comprises a set of configurable parameters and decision trees able to implement AI algorithms in the sensor itself. The kinds of algorithms suitable for the Machine Learning Core can be implemented by following an inductive approach, which involves searching patterns from observations.

The idea behind the Machine Learning Core is to use the accelerometer, gyroscope, and external sensor data (readable through the I<sup>2</sup>C master interface) to compute a set of statistical parameters selectable by the user (such as mean, variance, energy, peak, zero crossings, etc.) in a defined time

window. In addition to the sensor input data, some new inputs can be defined by applying some configurable filters available in the device.

The Machine Learning Core parameters are called “Features” and can be used as input for a configurable decision tree that can be stored in the device. The decision tree, which can be stored in the LSM6DSOX, is a binary tree composed of a series of nodes. A statistical parameter (feature) is evaluated against a threshold to establish the evolution in the next node and this in each node. When a leaf (one of the last nodes of the tree) is reached, the decision tree generates a readable result through a dedicated device register. Using this innovative architecture, we can target from 10 to 1000 times energy saving.

The environmental monitoring system exploits the range of State-of-the-art IoT sensor nodes and communication protocols to deliver data to Vranken Pommery to aid the decision-making process. As described above, the IoT sensor node provided includes different sensing technologies to provide real-time data related to weather, soil, crop water status, soil salinity. With the latest development of wireless communication technologies, sensor data can be accessed rapidly and at a relatively low cost, saving Pommery potentially significant amounts of time and money.

Since IoT sensor nodes are battery-powered, the right combination of low-power sensors and communication networks is imperative for the environmental monitoring system. In addition, the sensors used in this demo require low bandwidth due to the small size of the transmitted data packets. Thus, LPWANs are the best suited wireless communication protocols for this demo due to their low power consumption and long communication distance. LoRaWAN is one well-established protocol in the LPWAN family, it uses Long-Range (LoRa) modulation in its physical layer, and it is characterised by extended and significant coverage and low data rate with low complexity assuring optimal power consumption. Using LoRaWAN, a large volume of data from multiple sensor types installed in multiple vineyards of Vranken-Pommery are generated. Therefore a data management system composed of a distributed data system formed by the IIoT nodes previously described and a centralised data system collecting sensor data from the distributed data system and providing access to data via ad-hoc methods is required. This system aims to enable time-series data collection, processing, and storage. In order to have a user-friendly approach to managing the acquired data, it is also crucial to present and visualise data via a complete end-to-end infrastructure based on Grafana. Using Grafana, we can pull data from the database, allowing us to create customised and attractive charts and graphs. Dashboards



provide the real value of the monitoring parameters and use computational models and algorithms to translate data to useful information to Vranken-Pommery to make actionable decisions. The introduction of an efficient and scalable data management system allows managing larger datasets that may cover multiple Vranken-Pommery vineyards. Managing the collected datasets effectively makes it possible to exploit further prediction (AI) opportunities in the Cloud that are infeasible with smaller siloed datasets.

#### **4.1.6 Conclusion**

This article presents a monitoring system demonstrating how an AI-based energy-efficient IIoT solution using LoRaWAN connectivity can be used in Champagne production. The trends in moving computation from the cloud to the edge are summarised, and the implication of IIoT end nodes design and architecture is discussed. It is crucial to connect many sensors to each IIoT end node to give the flexibility to address several use cases in champagne production. We have also proposed to deploy machine learning on IIoT end nodes. The article described the way to enable the execution of machine learning models on hardware with low performances based on STM32 MCU to reduce the network data transmission by allowing computations to be performed close to the sensor data sources, preserving privacy in uploading data, and reducing power consumption for continuous wireless communication to cloud servers. Finally, the article describes the deployment of a system monitoring infrastructure based on LoRaWAN for the monitoring of environmental conditions within the vineyards of Vranken Pommery.

#### **Acknowledgements**

This work is conducted under the framework of the ECSEL AI4DI “Artificial Intelligence for Digitising Industry” project. The project has received funding from the ECSEL Joint Undertaking (JU) under grant agreement No 826060. The JU receives support from the European Union’s Horizon 2020 research and innovation programme and Germany, Austria, Czech Republic, Italy, Latvia, Belgium, Lithuania, France, Greece, Finland, Norway.

#### **References**

- [1] Farmwave. Available online at: <https://www.cadre-ai.com/agriculture>
- [2] Plantix. Available online at: <https://plantix.net/en/>
- [3] CropX. Available online at: <https://cropx.com/>

- [4] PlantVillage Nuru. Available online at: <https://plantvillage.psu.edu/>
- [5] Precisionhawk. Available online at: <https://www.precisionhawk.com/agriculture>
- [6] Blue River Technology Project. Available online at: <https://bluerivertechhnology.com/>
- [7] aWhere. Available online at: <https://www.awhere.com/about/>
- [8] Microstrain. Available online at: <https://www.microstrain.com/applications/sensorcloud-enables-condition-based-agriculture-shelburne-vineyard>
- [9] Taranis. Available online at: <https://taranis.ag/about-us/>
- [10] Raza, U., Kulkarni P. and Sooriyabandara, M.. (2017). “Low Power Wide Area Networks: An Overview,” in *IEEE Communications Surveys & Tutorials*, vol. 19, no. 2, pp. 855-873, Second quarter 2017. <https://doi:10.1109/COMST.2017.2652320>
- [11] Sanchez-Iborra R, G. Liaño I, Simoes C, Couñago E, Skarmeta AF. (2019). Tracking and Monitoring System Based on LoRa Technology for Lightweight Boats. *Electronics*. 2019; 8(1):15. <https://doi.org/10.3390/electronics8010015>
- [12] Mekki, K.; Bajic, E.; Chaxel, F.; Meyer, F. A comparative study of LPWAN technologies for large-scale IoT deployment. *ICT Express* 2019, Vol. 5, Issue 1, pp. 1–7. Available online at: <https://www.sciencedirect.com/science/article/pii/S2405959517302953?via%3Dihub>
- [13] Lee D.D., Seung H.S. (1999). WOES’99: Proceedings of the Workshop on Embedded Systems on Workshop on Embedded Systems. USENIX Association; Berkeley, CA, USA: 1999. Learning in intelligent embedded systems; p. 9.
- [14] Haigh K.Z., Mackay A.M., Cook M.R., Lin L.G. (2015). *Machine Learning for Embedded Systems: A Case Study*. BBN Technologies; Cambridge, MA, USA: 2015. Technical Report.
- [15] Chen J., Ran X. (2019). Deep Learning with Edge Computing: A Review. *Proc. IEEE*. 2019; 107:1655–1674. <https://doi:10.1109/JPROC.2019.2921977>
- [16] Sze V., Chen Y.H., Emer J., Suleiman A., Zhang Z. (2017). Hardware for machine learning: Challenges and opportunities; *Proceedings of the 2017 IEEE Custom Integrated Circuits Conference (CICC)*; Austin, TX, USA. 30 April–3 May 2017; pp. 1–8.
- [17] X-CUBE-AI—AI Expansion Pack for STM32CubeMX—STMicroelectronics. Available online at: <https://www.st.com/en/embedded-software/x-cube-ai.html#overview>

- [18] Polonelli, T.; Brunelli, D.; Marzocchi, A.; Benini, L. (2019). Slotted ALOHA on LoRaWAN-Design, Analysis, and Deployment. *Sensors* 2019, 19, 838. <https://doi.org/10.3390/s19040838>
- [19] LoRaWAN Architecture. Available online at: <https://air.imag.fr/index.php/File:Network.png>
- [20] LoRaWAN. The Things Network. Available online at: <https://www.thethingsnetwork.org/docs/lorawan/>